

COMUNE DI CARBONIA

PIANO DI RIQUALIFICAZIONE E RECUPERO
VARIANTE N. 2: VARIANTE GENERALE

Ufficio Tecnico Comunale
Settori Urbanistica e Tutela del Paesaggio

Progettisti :
Ing. Enrico Potenza
Ing. Erika Daga

Collaboratori:
Geom. Giorgio Airi
Geom. Marcello Floris

Visto il dirigente ufficio tecnico comunale :
Ing. Giampaolo Porcedda

il sindaco :
Giuseppe Casti
l' assessore :
Mauro Esu

ALLEGATO A

titolo
CENTRO MATRICE
PIANO DI RIQUALIFICAZIONE E RECUPERO
ABACHI DELLE MODIFICAZIONI
APPROVAZIONE

data
Marzo 2016

protocollo	nome file	formato
		.DWG

ABACHI DELLE MODIFICAZIONI



ABACO AMBITI DI INTERVENTO

- ambiti di intervento isolato 1
- ambiti di intervento isolati 2
- ambiti di intervento isolati 3

TIPOLOGIE EDILIZIE STORICHE CON ABACO

- operai Gra M
- operai Gra Mn
- operai Gra M modificata
- operai Gra N
- operai Gra Nn
- operai Santi normale
- operai Santi ridotta
- operai Lenti normale
- operai Lenti grande
- operai Lacchi normale
- operai D'Angelo
- operai Gra B
- operai XVIII Dicembre
- operai C



ABACO AMBITI DI INTERVENTO

- ambiti di intervento isolato 1
- ambiti di intervento isolati 2
- ambiti di intervento isolati 3

TIPOLOGIE EDILIZIE STORICHE CON ABACO

- operai Gra M
- operai Gra Mn
- operai Gra M modificata
- operai Gra N
- operai Gra Nn
- operai Santi normale
- operai Santi ridotta
- operai Lenti normale
- operai Lenti grande
- operai Lacchi normale
- operai D'Angelo
- operai Gra B
- operai XVIII Dicembre
- operai C

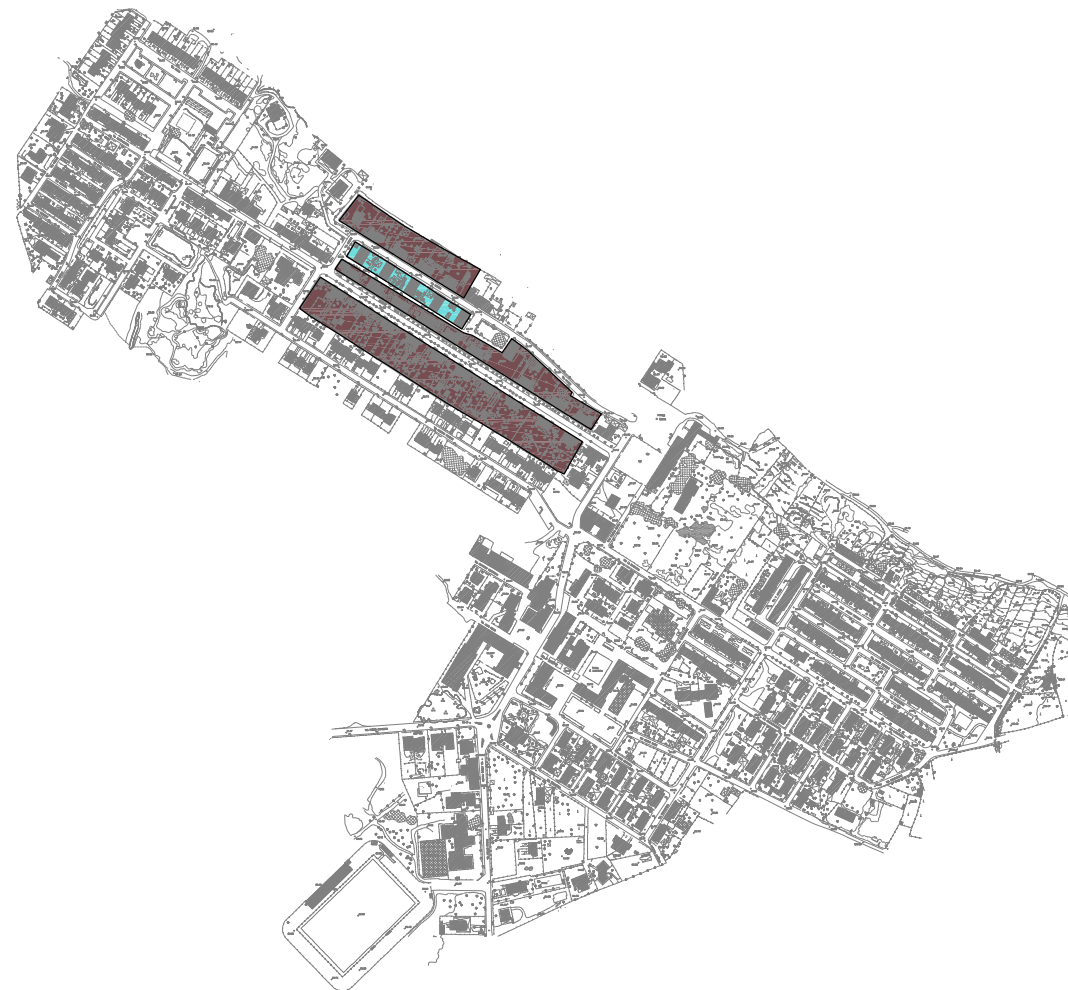

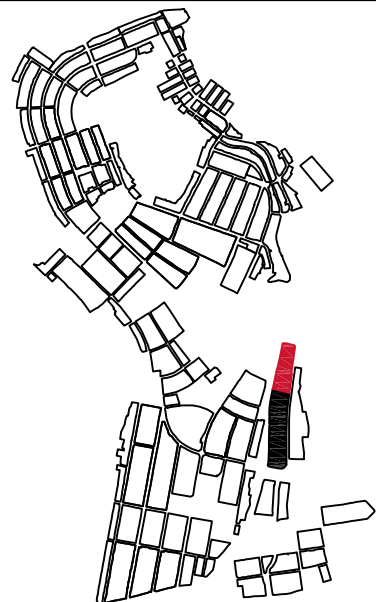

LOCALIZZAZIONE
Carbonia

- progetto guida di riferimento
- ambiti di intervento analoghi

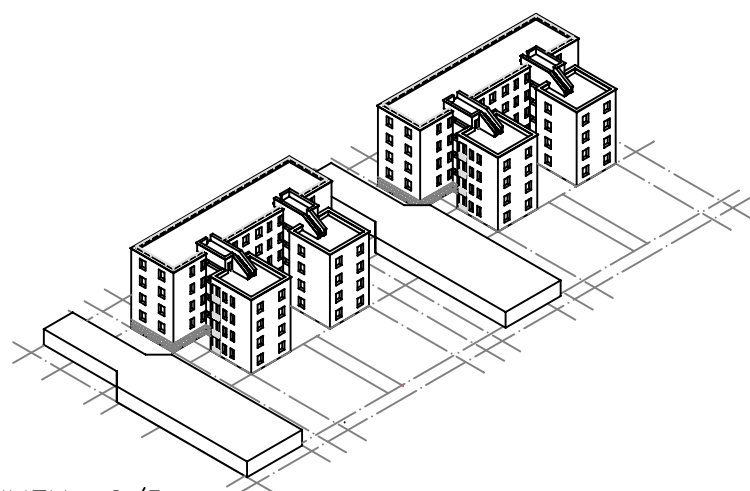
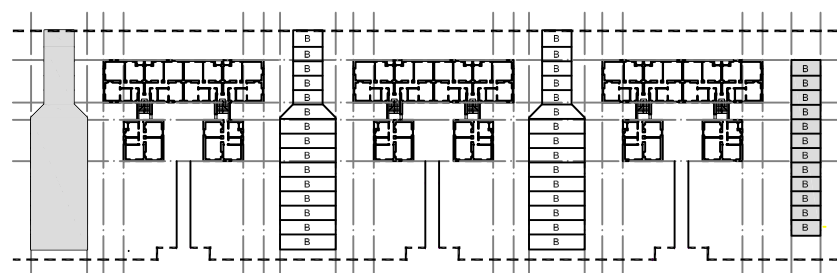
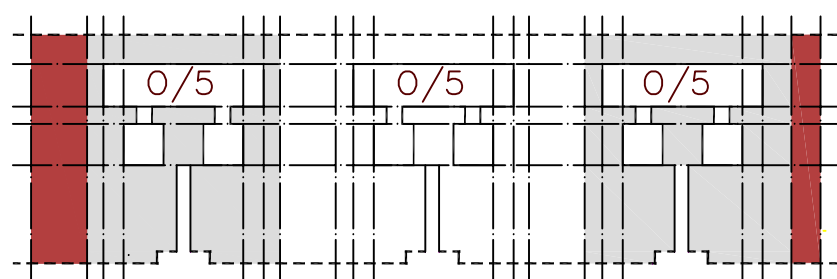

TIPOLOGIA EDILIZIA: 0/5

CARATTERISTICHE ARCHITETTONICHE: un solido a pianta rettangolare, con due alloggi per piano (uguali fra loro), e da due corpi a pianta quadrata, con un alloggio per piano, disposti simmetricamente e collegati mediante due vani scala.

STRUTTURA ISOLATO: unica fila di edifici con disposizione parallela all'asse stradale e distacco dal fronte strada

RIFERIMENTI: -

FASCE DI EDIFICABILITA'

- ambiti di edificabilità di tipo residenziale controllata
- ambiti di edificabilità di tipo non residenziale controllata
- ambiti non edificabili
- edificio di fondazione
- A corpo residenziale
- B rimesse e corpi accessori
- recinzioni

NOTE

Le nuove aggiunte residenziali non devono alterare la percezione dei caratteri architettonici peculiari dell'edificio di fondazione su cui vanno ad inserirsi, allo stesso modo le aggiunte di corpi accessori non residenziali non devono intasare i lotti ma devono concorrere alla ridefinizione della struttura originale dell'isolato.

ISOLATI TIPO 2

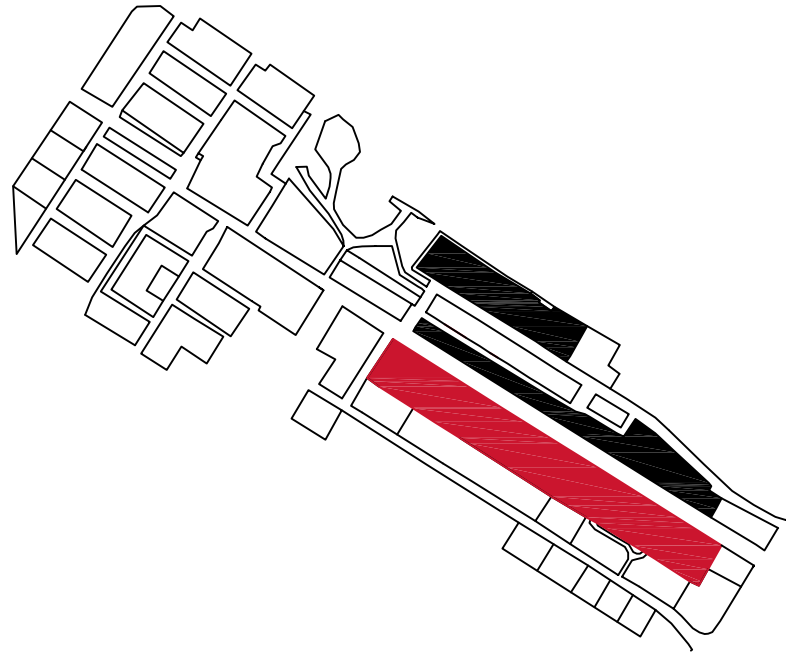

ISOLATI TIPO 3

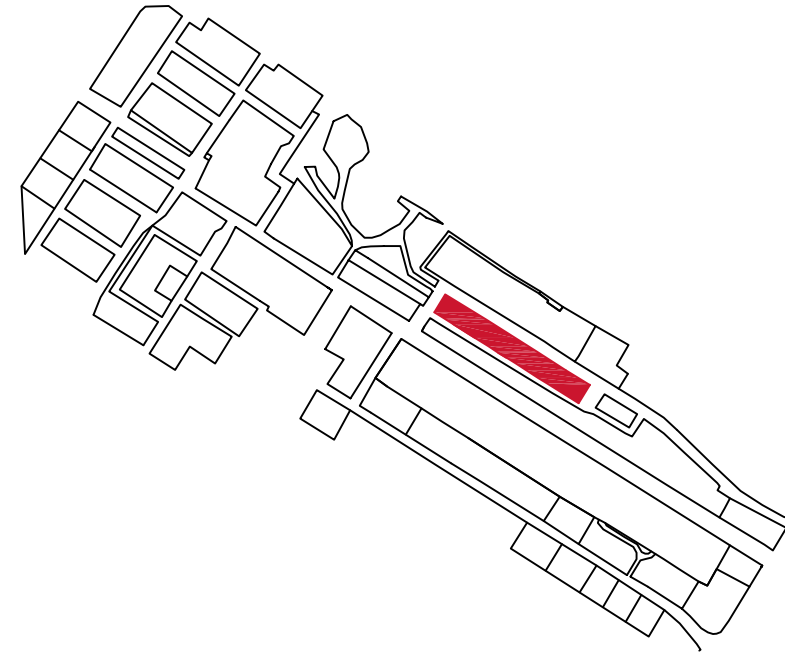

LOCALIZZAZIONE

Bacu Abis

- progetto guida di riferimento
- ambiti di intervento analoghi

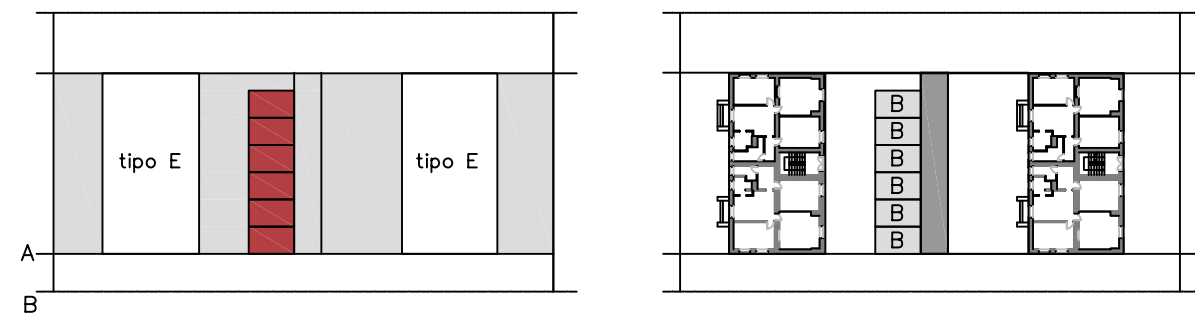
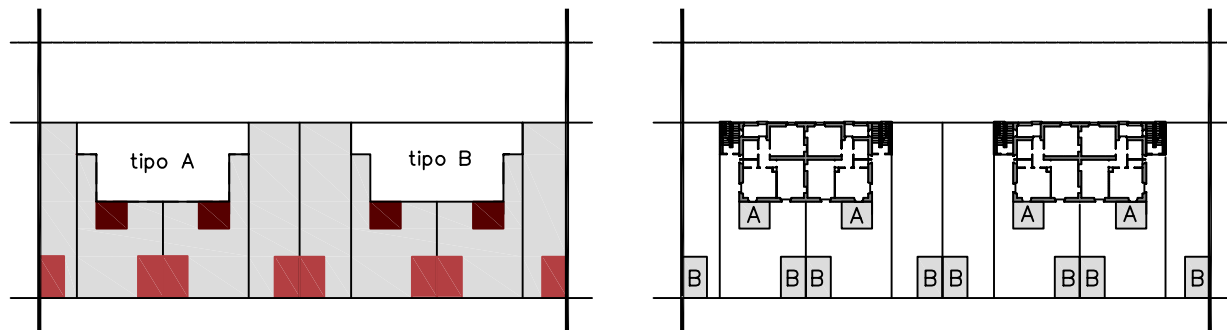

FASCE DI EDIFICABILITA'

- ambiti di edificabilità di tipo residenziale controllata
- ambiti di edificabilità di tipo non residenziale controllata
- ambiti non edificabili
- edificio di fondazione
- A corpo residenziale
- B rimesse e corpi accessori
- percorsi interni di collegamento

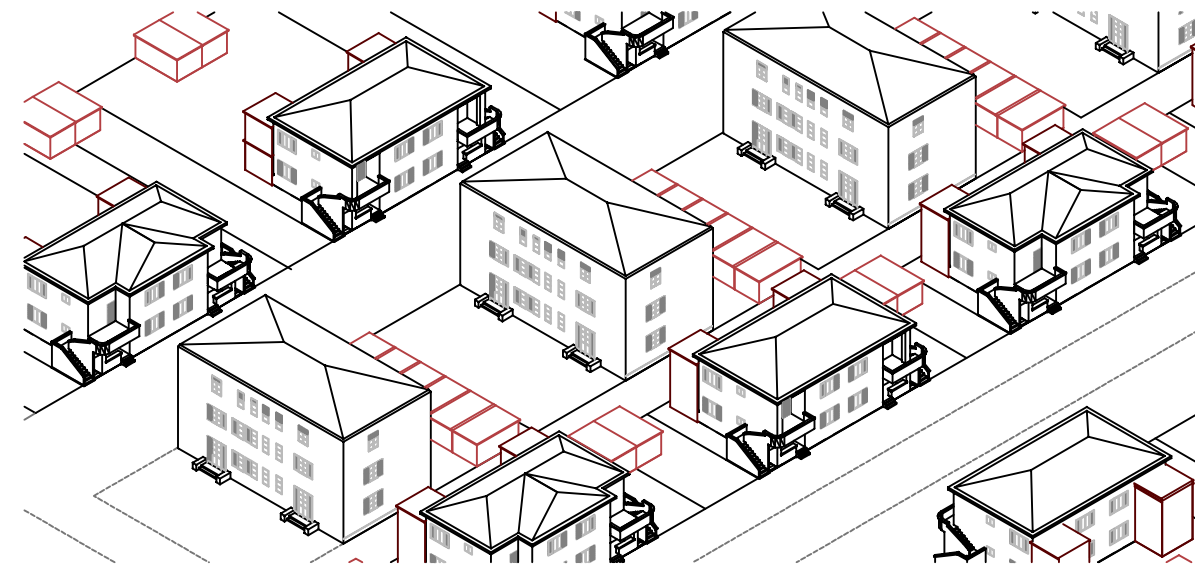
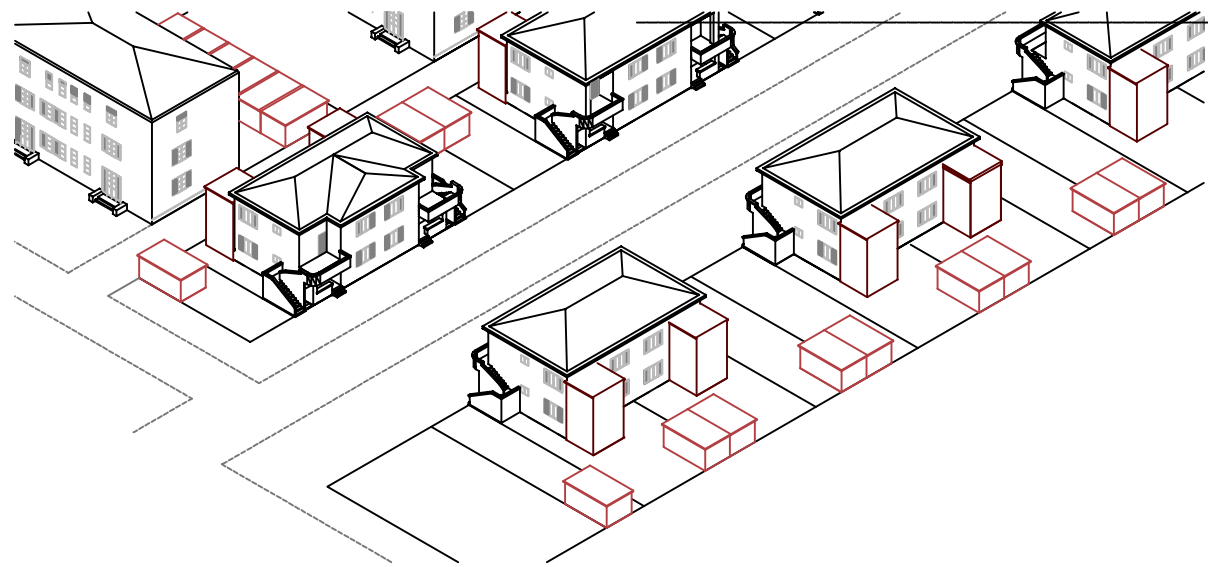

TIPOLOGIA EDILIZIA: tipologie A e B
 CARATTERISTICHE ARCHITETTONICHE: dovranno rispettare quanto disposto nelle Norme Tecniche di Attuazione all'art.6 "Norme di carattere generale".
 STRUTTURA ISOLATO: una fila di edifici Tipo A e B con disposizione parallela all'asse stradale con assenza di distacco dal fronte strada
 RIFERIMENTI: progetto guida 2.2

TIPOLOGIA EDILIZIA: tipologie E
 CARATTERISTICHE ARCHITETTONICHE: dovranno rispettare quanto disposto nelle Norme Tecniche di Attuazione all'art.6 "Norme di carattere generale".
 STRUTTURA ISOLATO: una fila di edifici Tipo E con disposizione trasversale all'asse stradale.
 RIFERIMENTI: progetto guida 2.2

NOTE
 Le nuove aggiunte residenziali non devono alterare la percezione dei caratteri architettonici peculiari dell'edificio di fondazione su cui vanno ad inserirsi, allo stesso modo le aggiunte di corpi accessori non residenziali non devono intasare i lotti ma devono concorrere alla ridefinizione della struttura originale dell'isolato.

TIPOLOGIA EDILIZIA OPERAI GRA-N
(e Tipologie GRA-N Modificata e GRA-N/N)

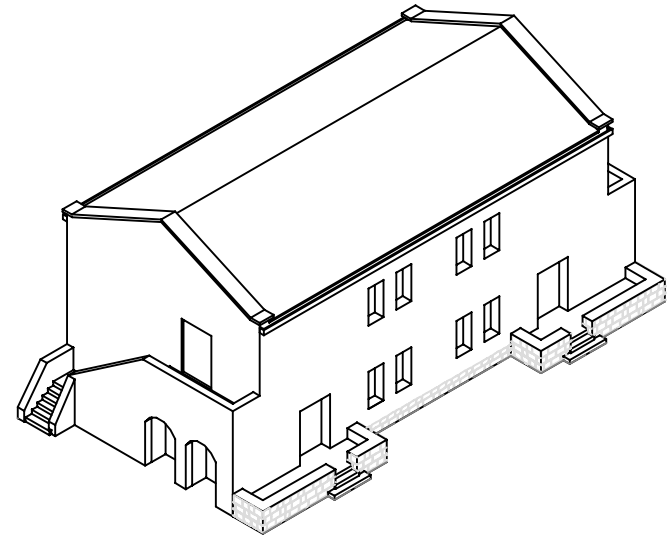
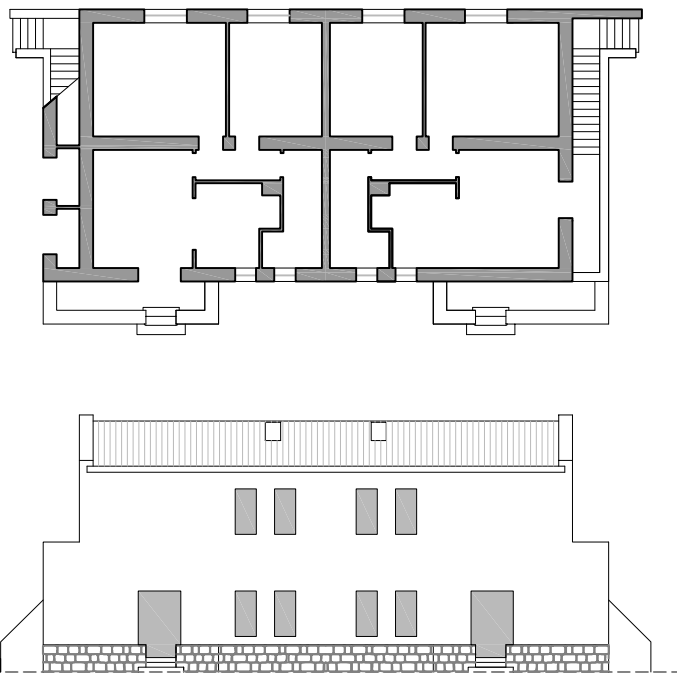

TIPOLOGIA EDILIZIA ORIGINARIA

TIPOLOGIA EDILIZIA OPERAI GRA-N
(e Tipologie GRA-N Modificata e GRA-N/N)

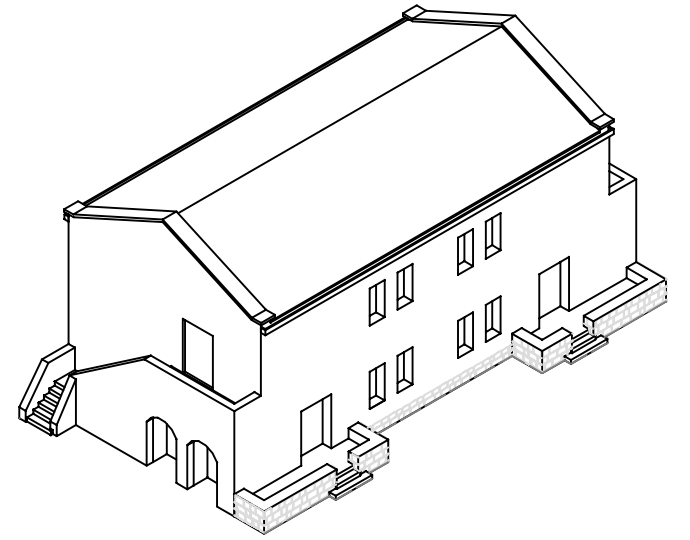
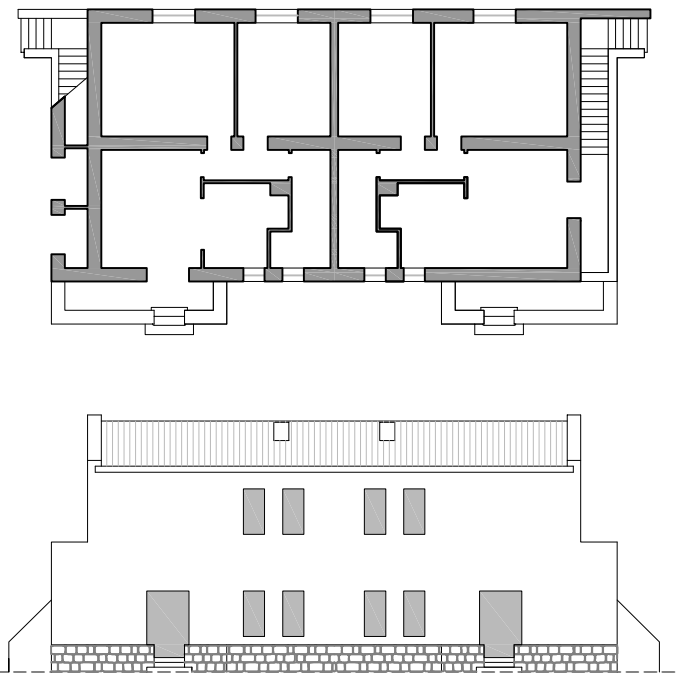

TIPOLOGIA EDILIZIA ORIGINARIA

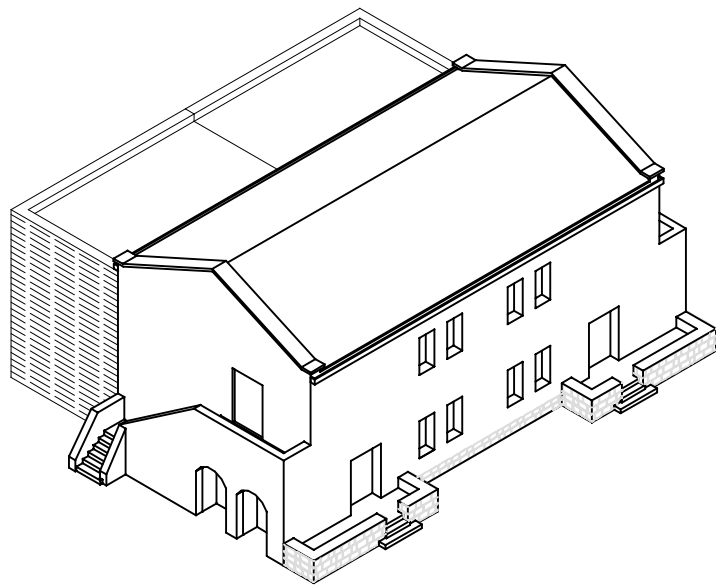
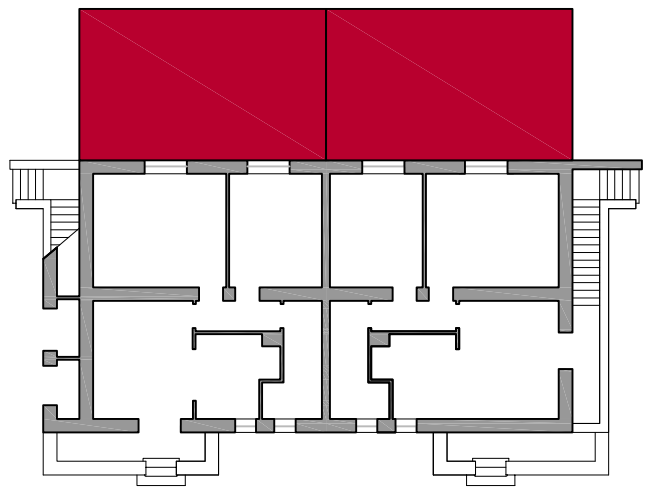

TIPOLOGIA EDILIZIA MODIFICATA

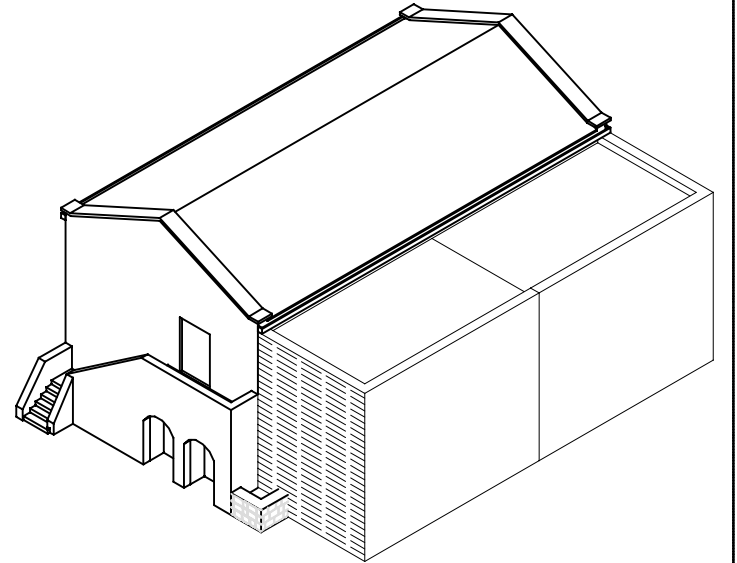
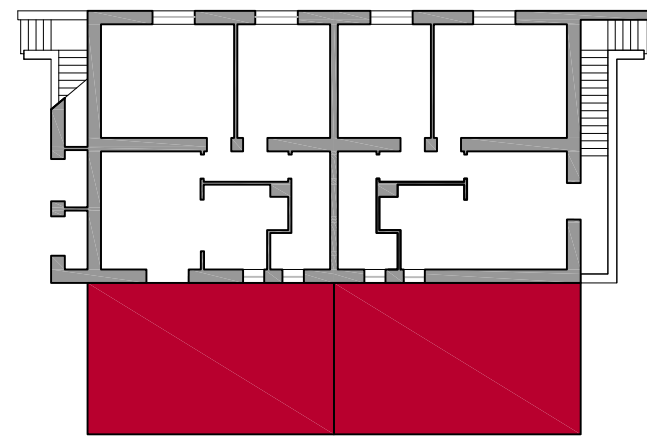

TIPOLOGIA EDILIZIA MODIFICATA

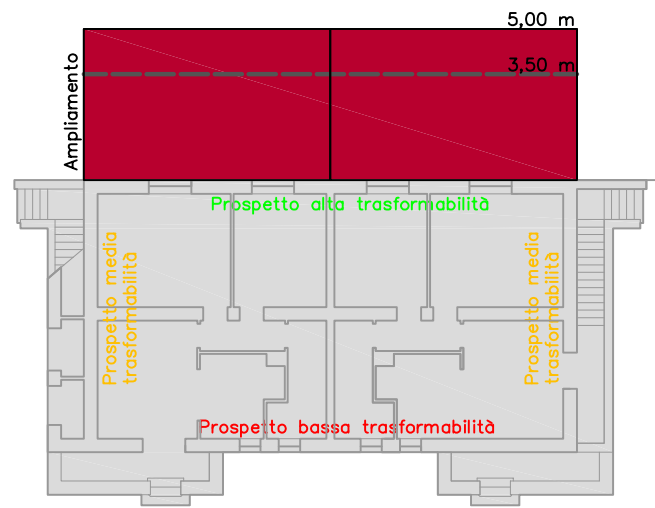

SCHEMA ABACO

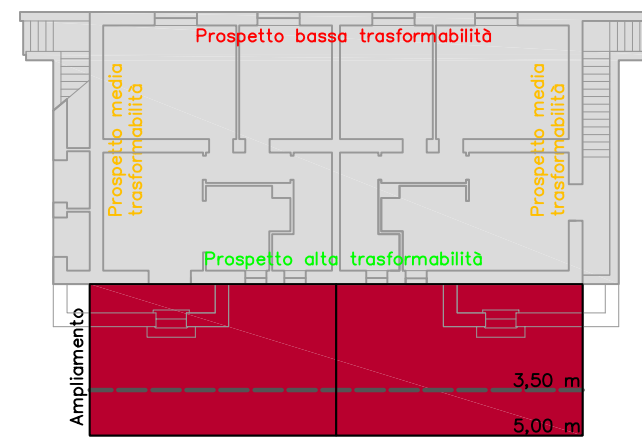

SCHEMA ABACO IN DEROGA

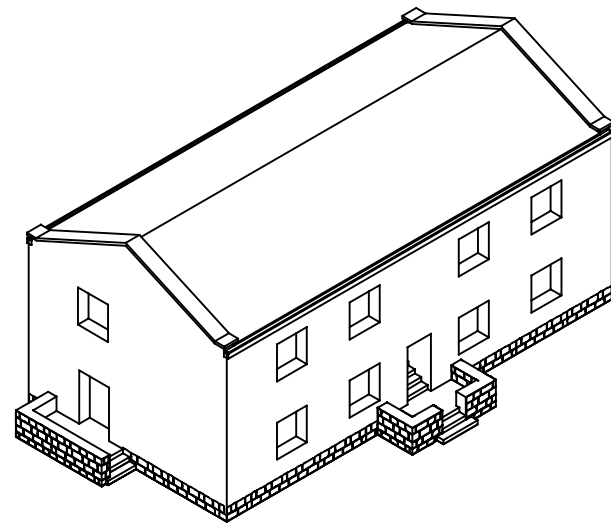
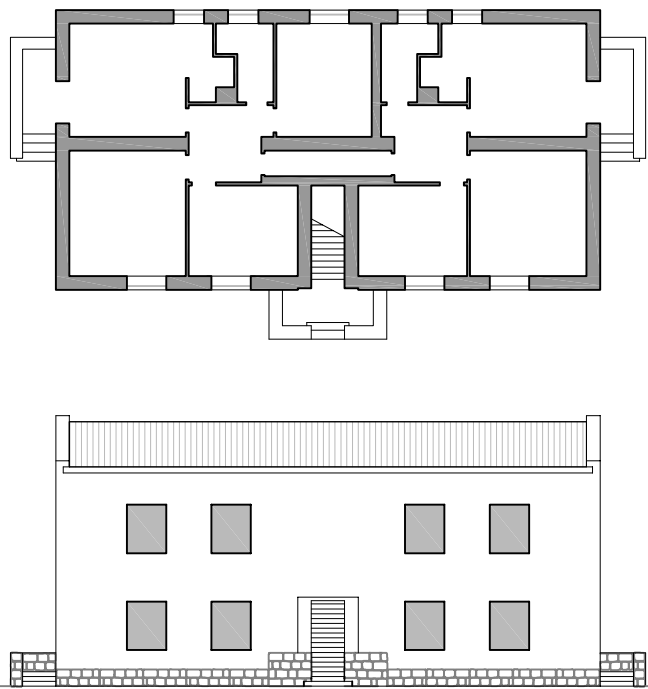

TIPOLOGIA EDILIZIA ORIGINARIA

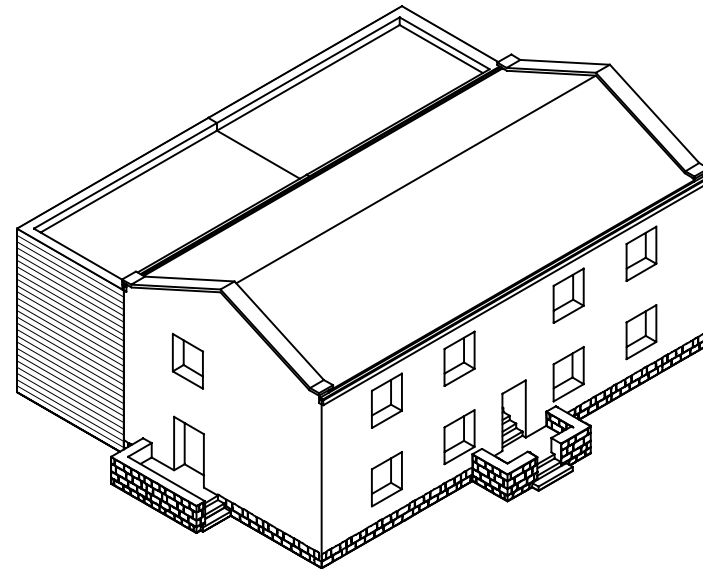
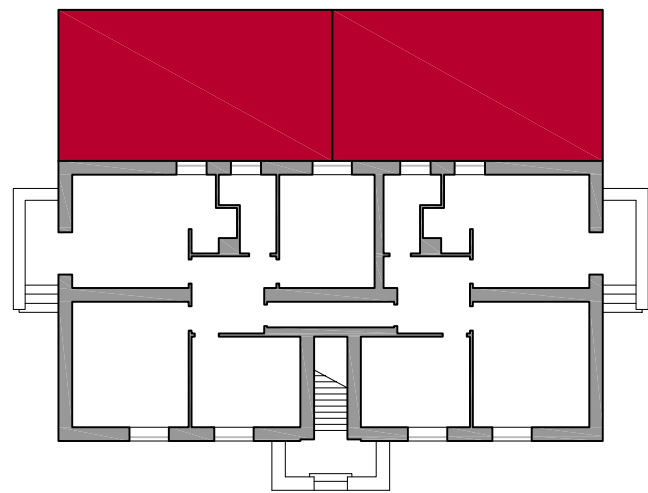

TIPOLOGIA EDILIZIA MODIFICATA

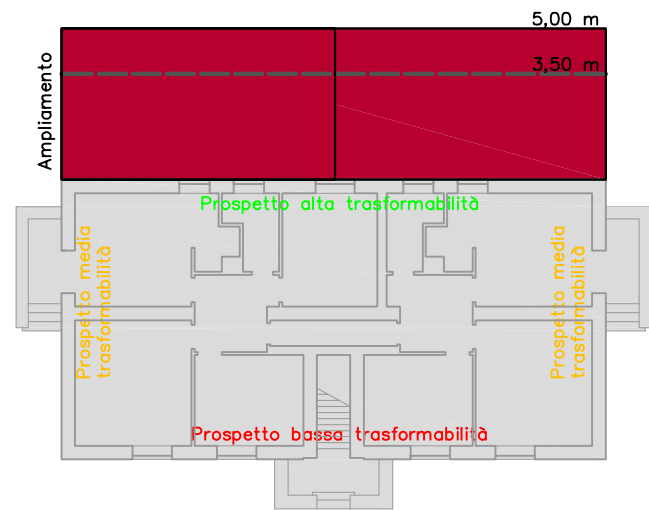

SCHEMA ABACO

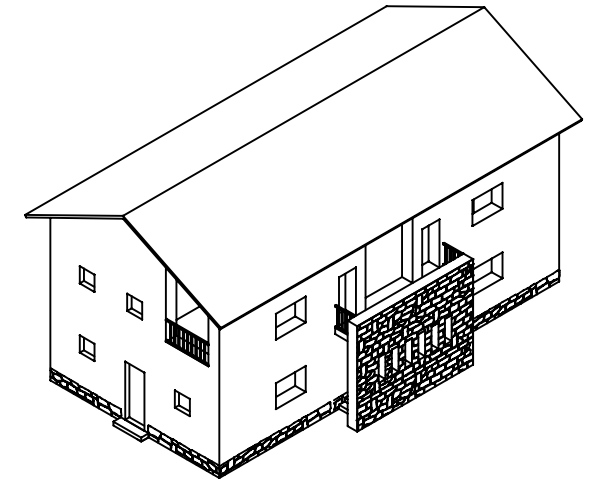
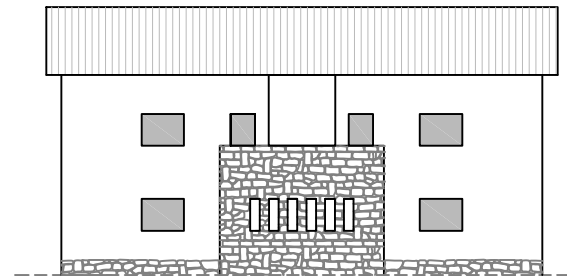
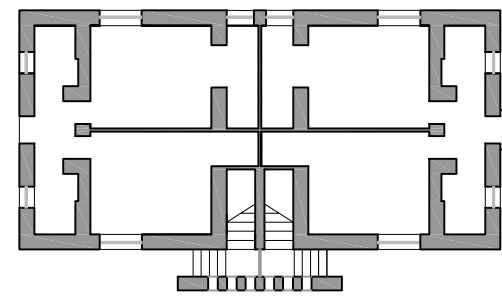

TIPOLOGIA EDILIZIA ORIGINARIA

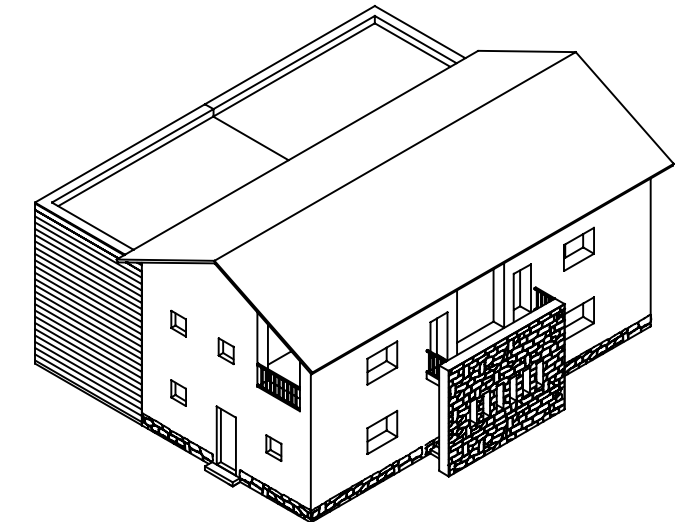
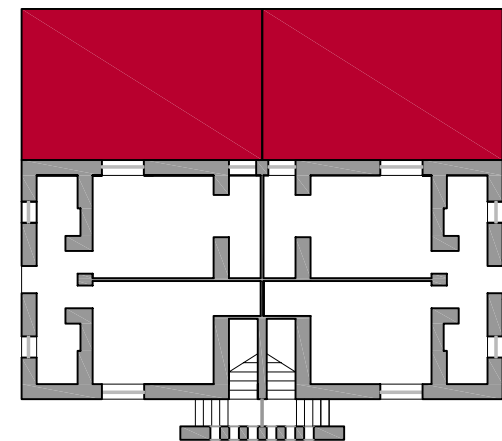

TIPOLOGIA EDILIZIA MODIFICATA

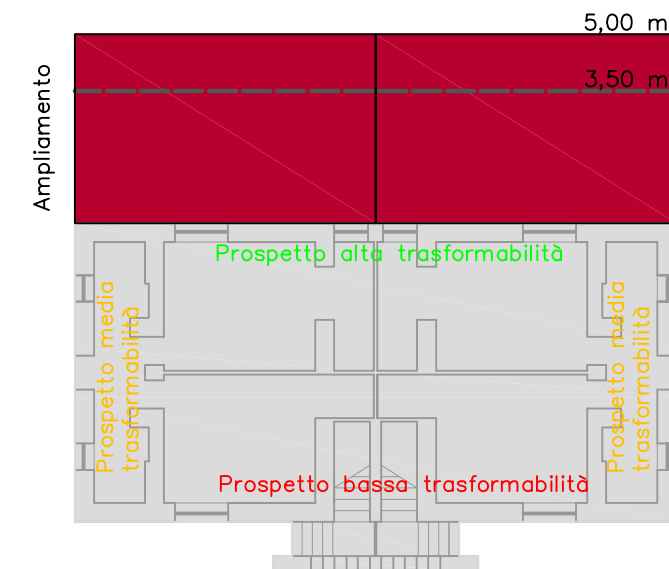

SCHEMA ABACO

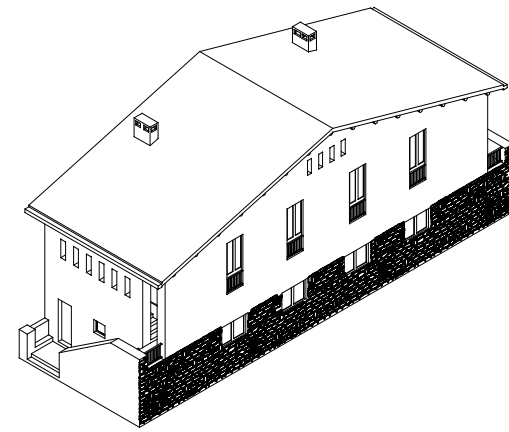
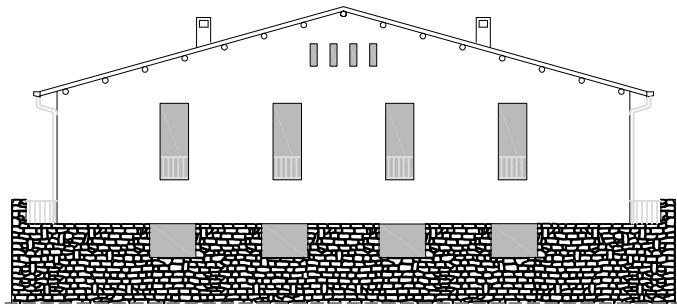
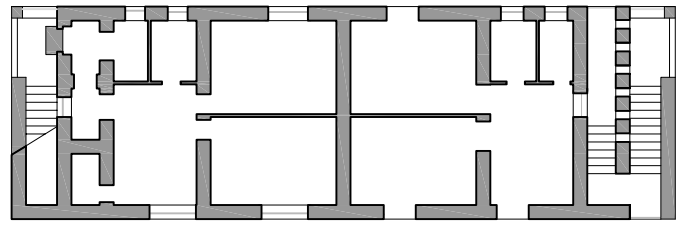

TIPOLOGIA EDILIZIA ORIGINARIA

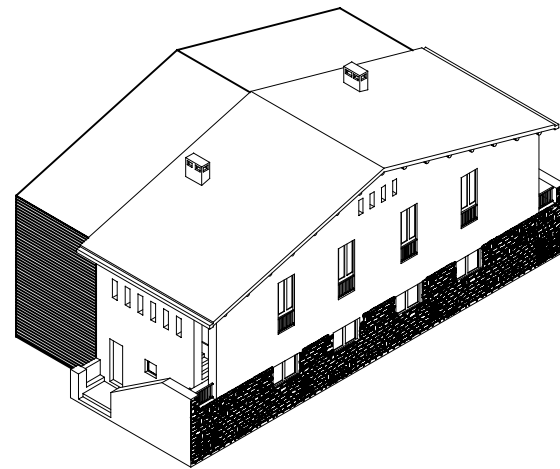
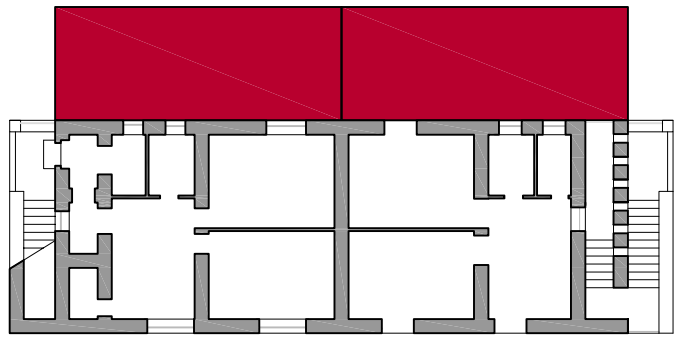

TIPOLOGIA EDILIZIA MODIFICATA

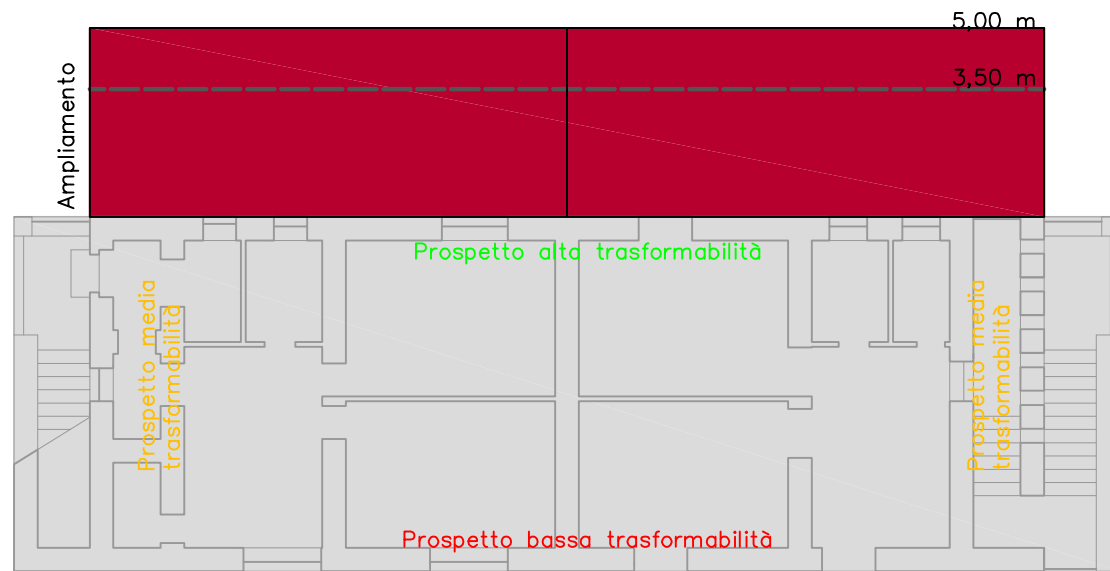

SCHEMA ABACO

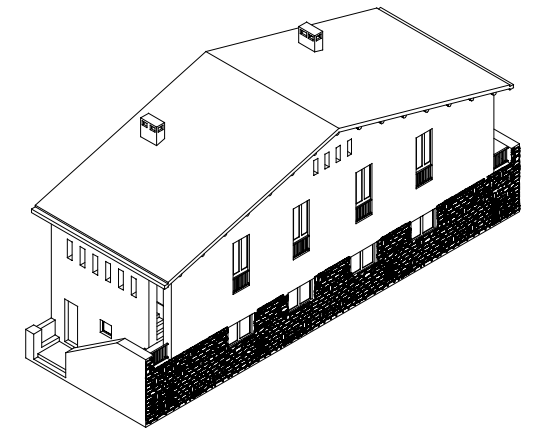
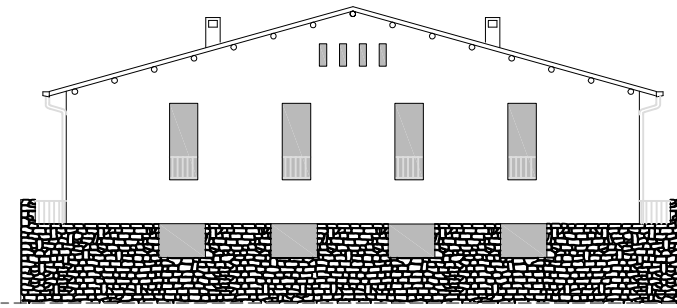
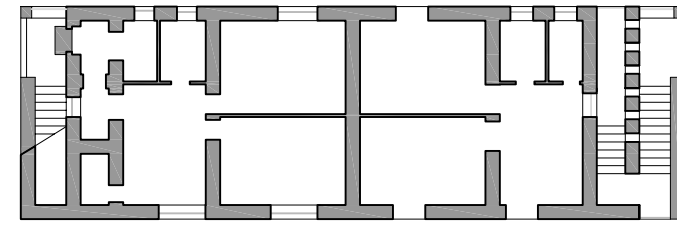

TIPOLOGIA EDILIZIA ORIGINARIA

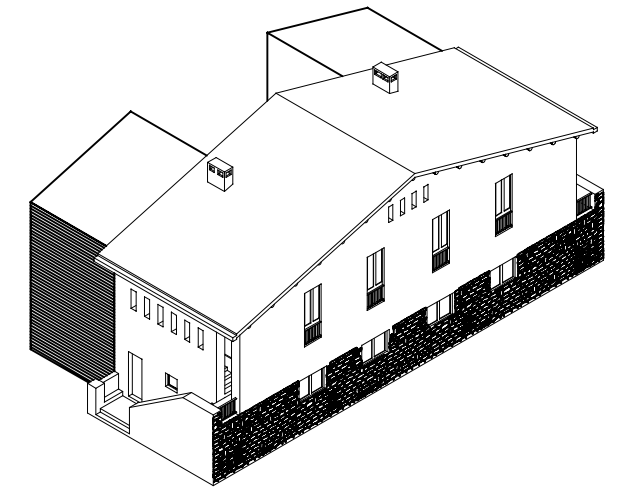
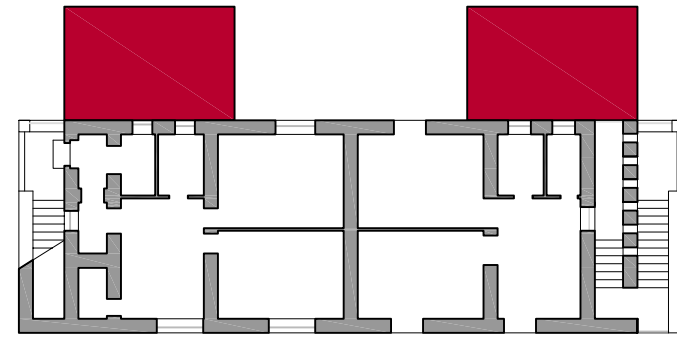

TIPOLOGIA EDILIZIA MODIFICATA

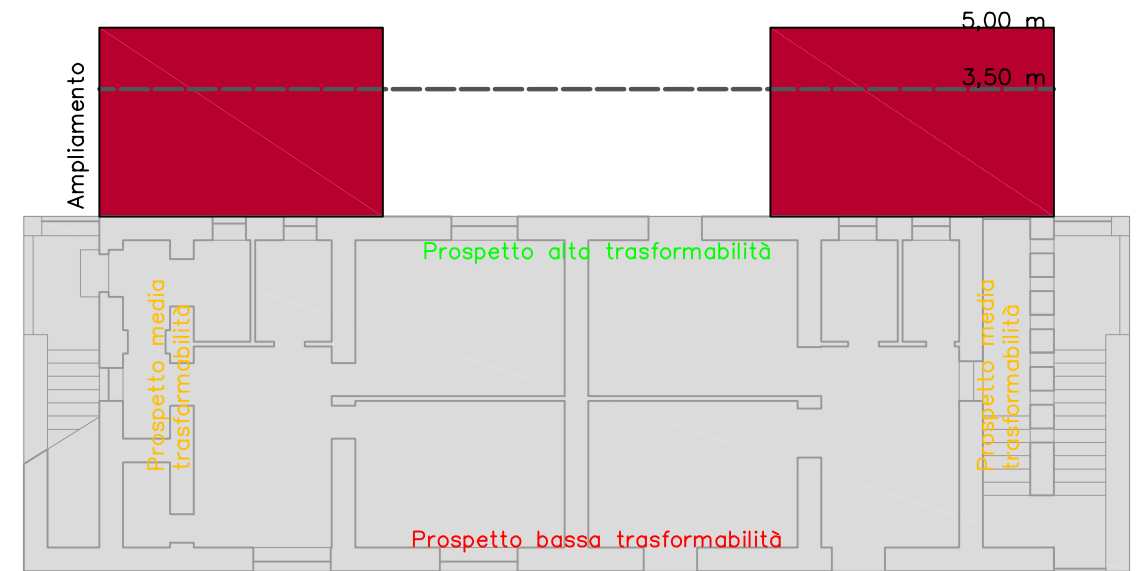

SCHEMA ABACO

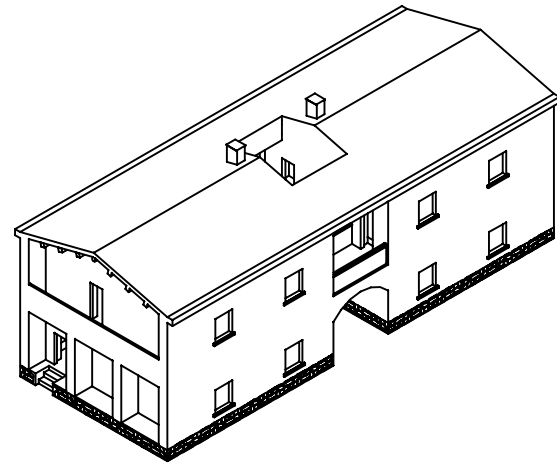
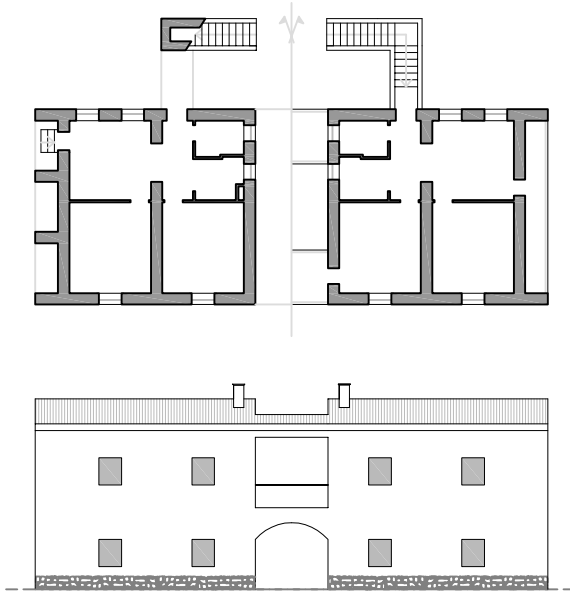

TIPOLOGIA EDILIZIA **ORIGINARIA**

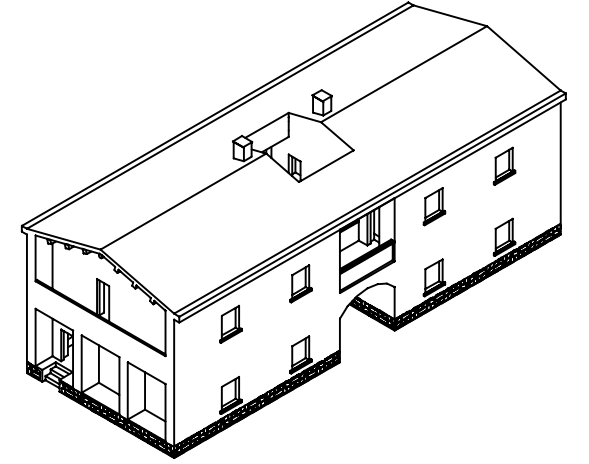
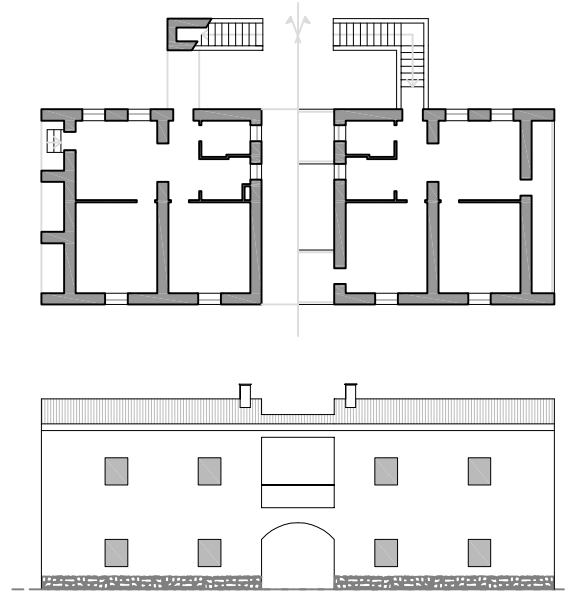

TIPOLOGIA EDILIZIA **ORIGINARIA**

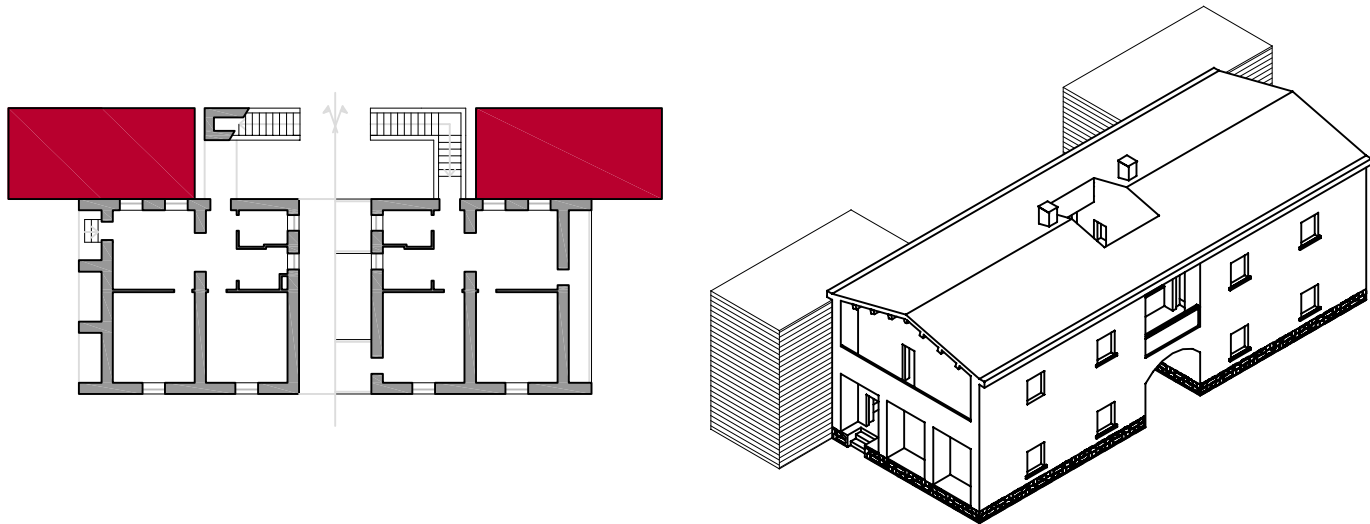

TIPOLOGIA EDILIZIA **MODIFICATA**

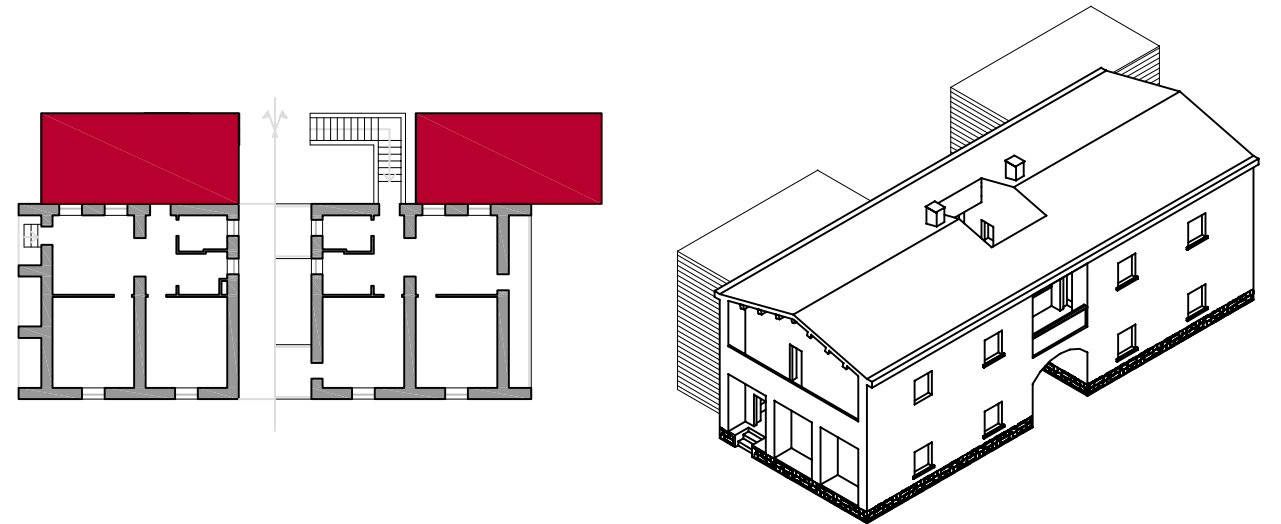

TIPOLOGIA EDILIZIA **MODIFICATA**

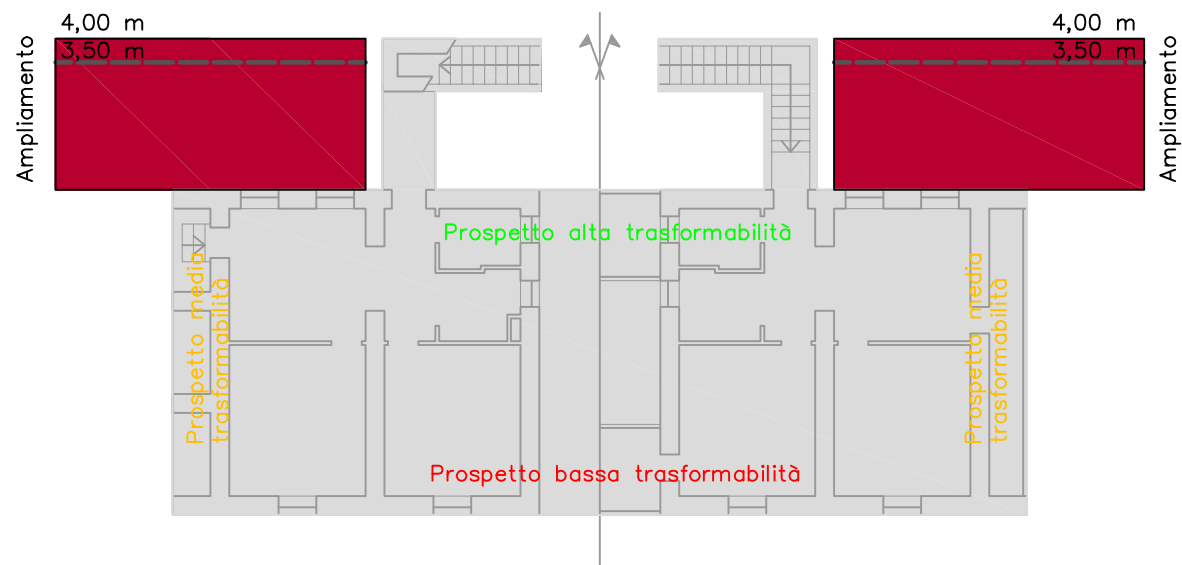

SCHEMA **ABACO**

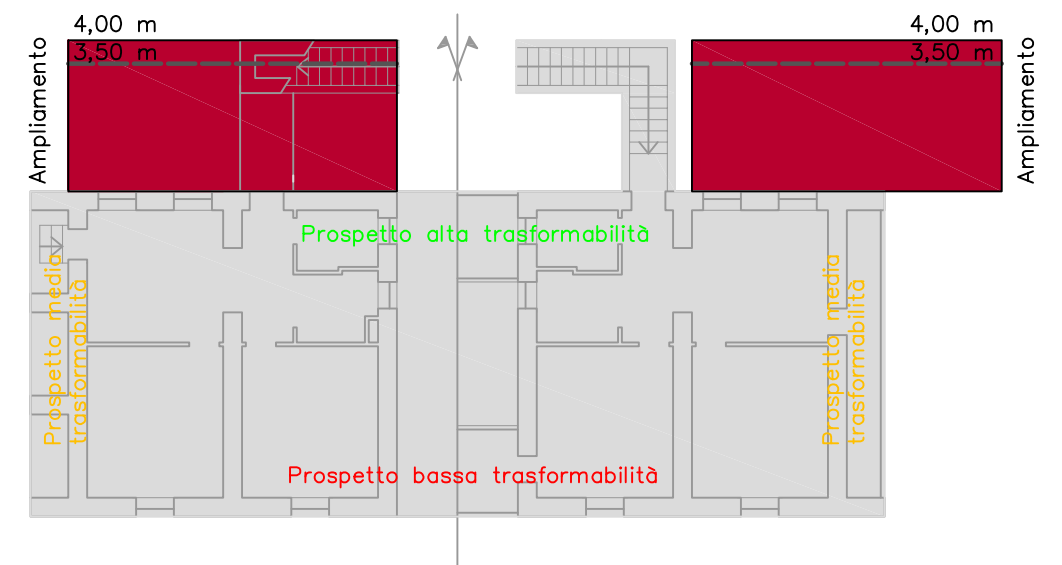

SCHEMA **ABACO**

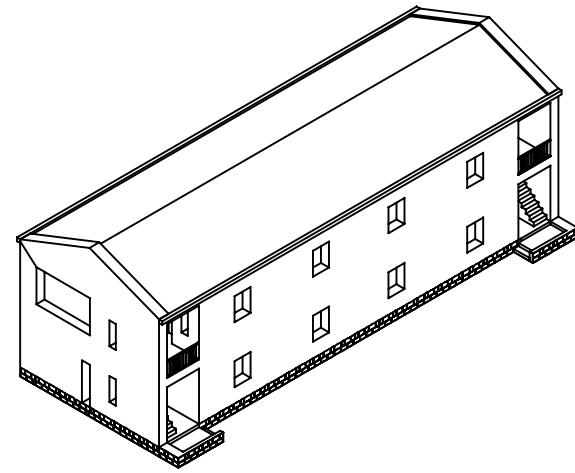
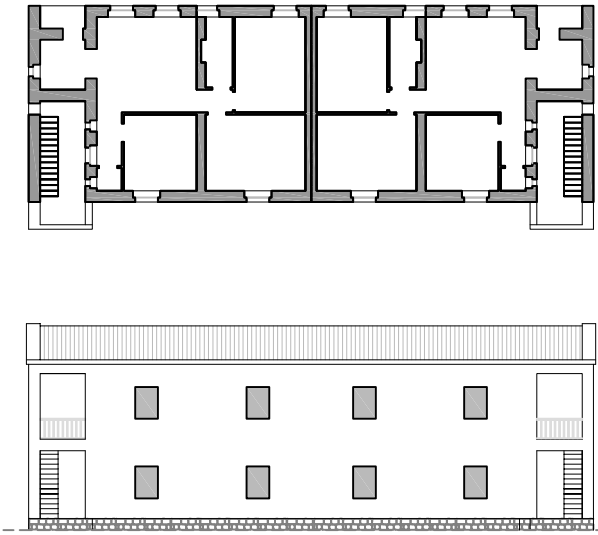

TIPOLOGIA EDILIZIA ORIGINARIA

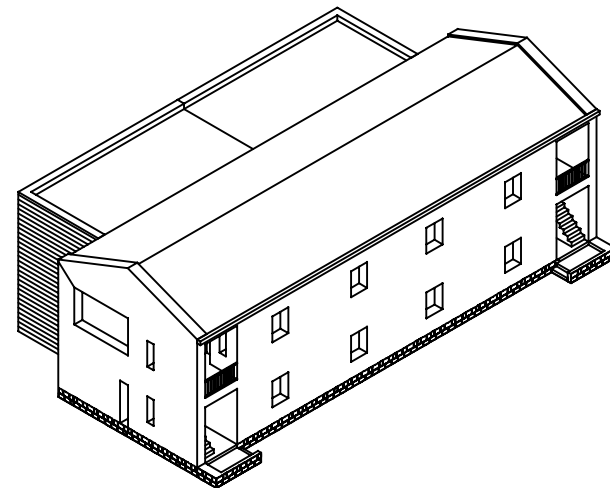
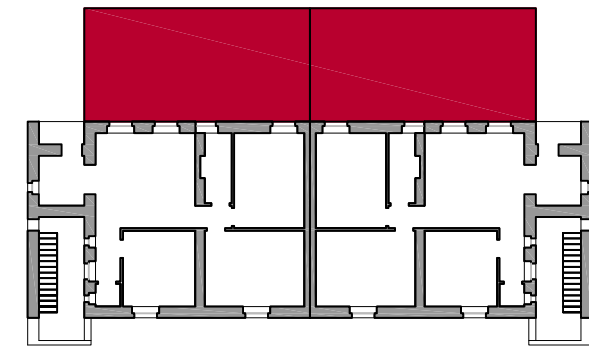

TIPOLOGIA EDILIZIA MODIFICATA

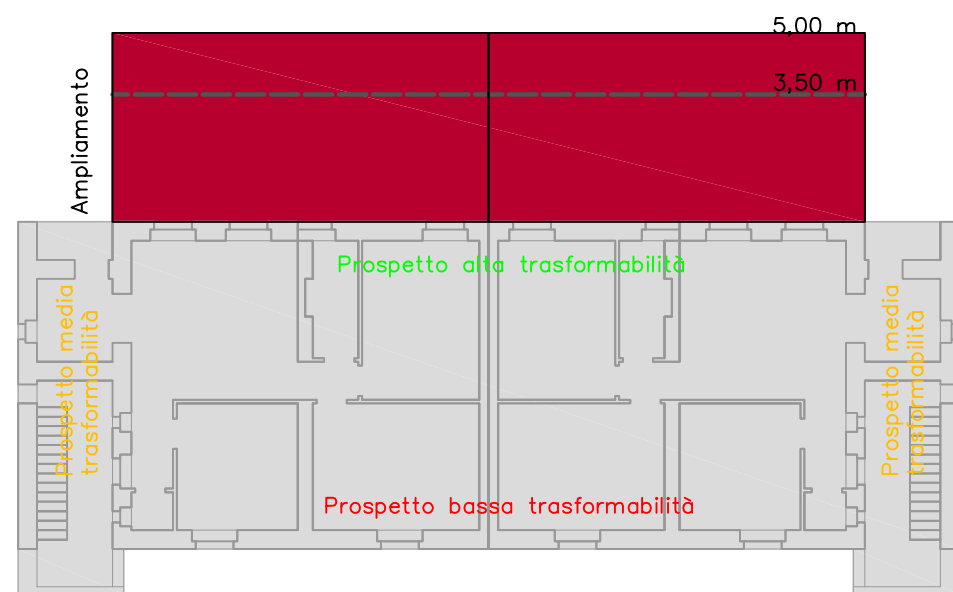

SCHEMA ABACO

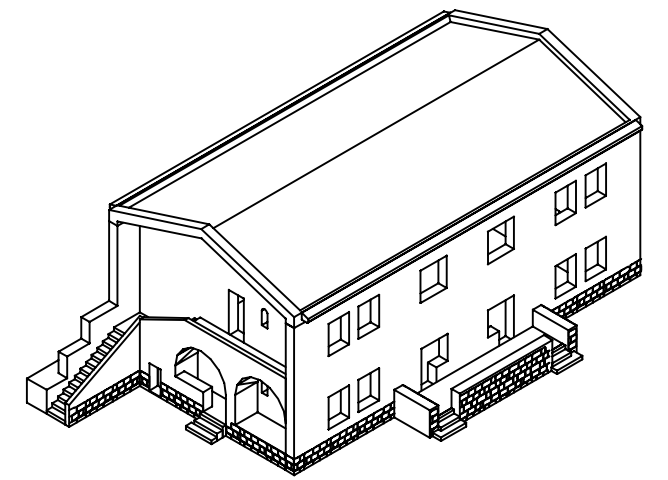
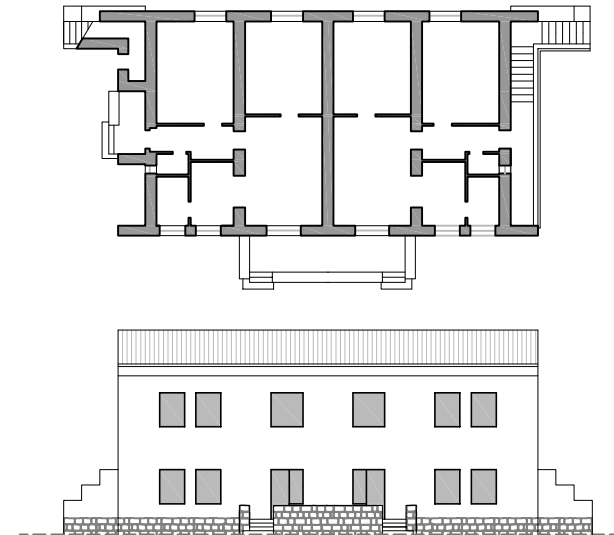

TIPOLOGIA EDILIZIA ORIGINARIA

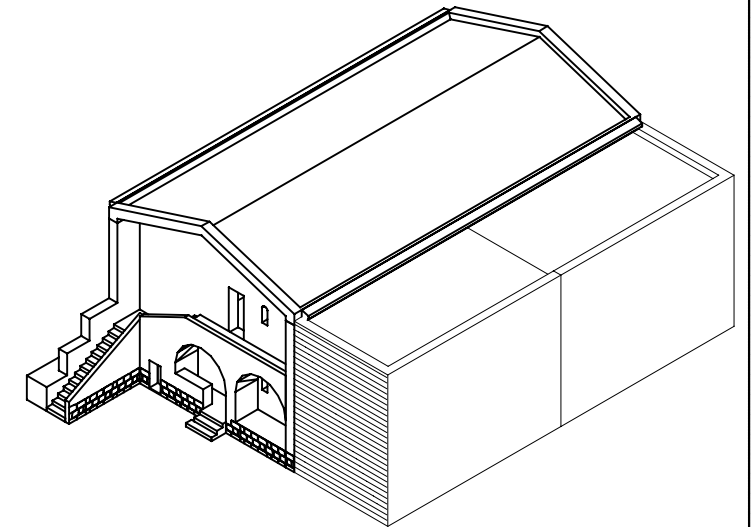
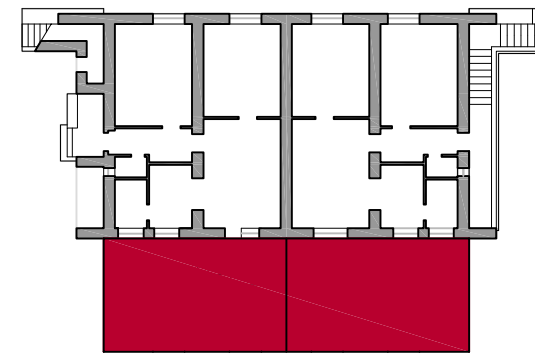

TIPOLOGIA EDILIZIA MODIFICATA

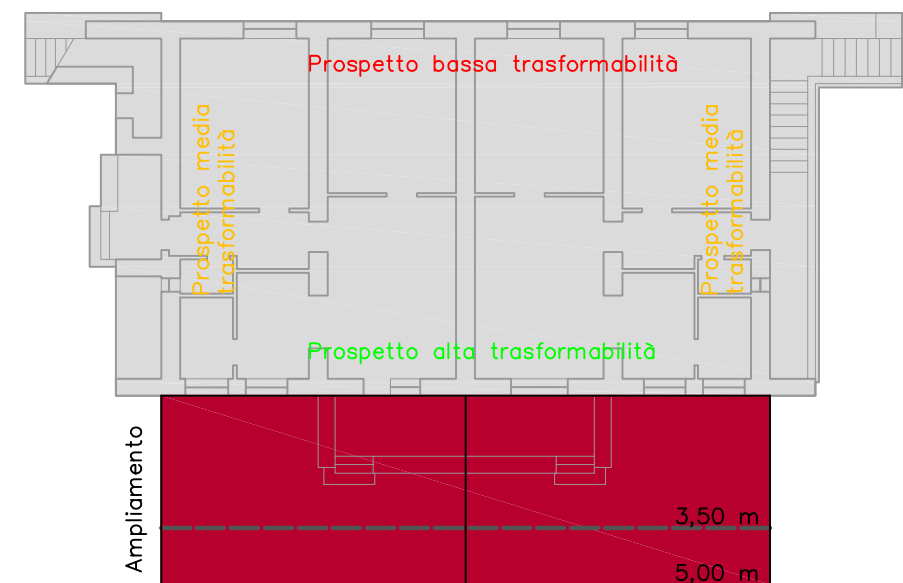

SCHEMA ABACO

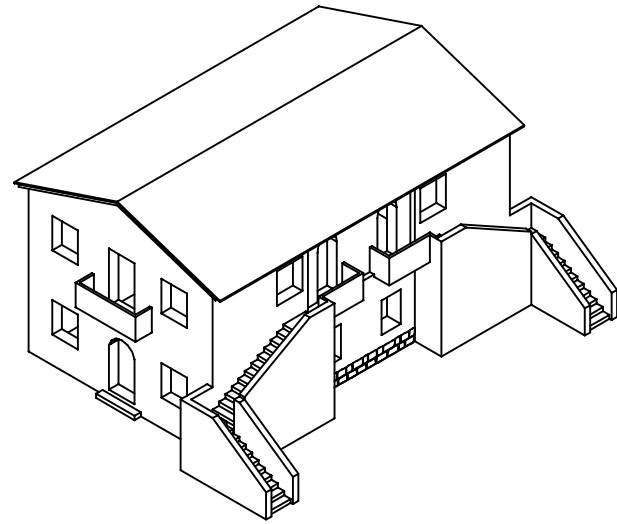
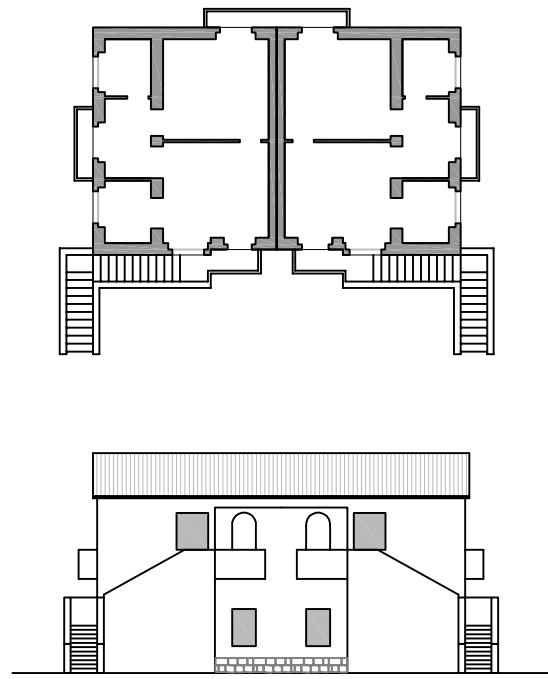

TIPOLOGIA EDILIZIA ORIGINARIA

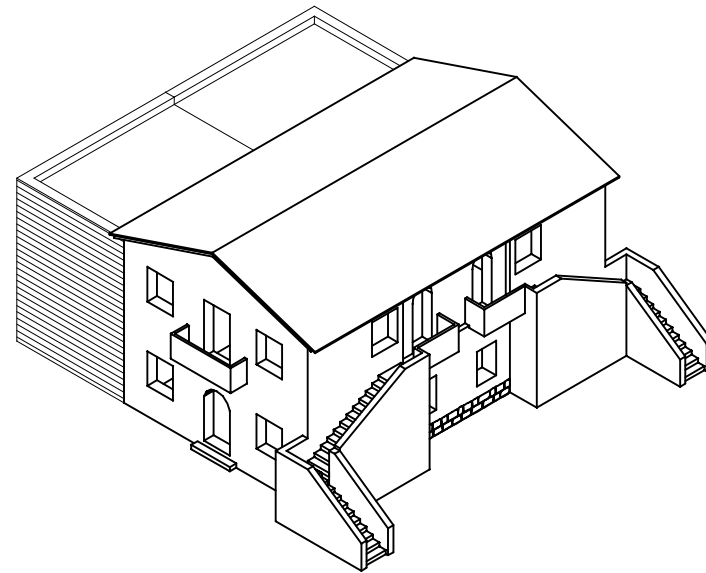
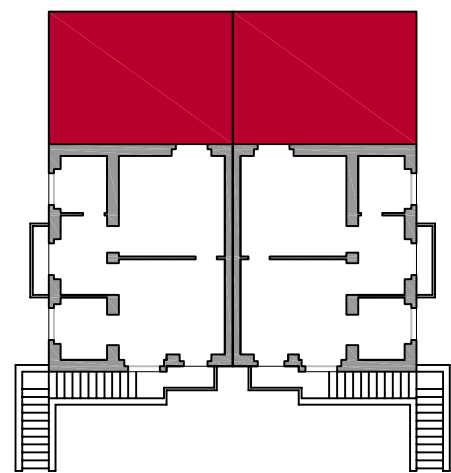

TIPOLOGIA EDILIZIA MODIFICATA

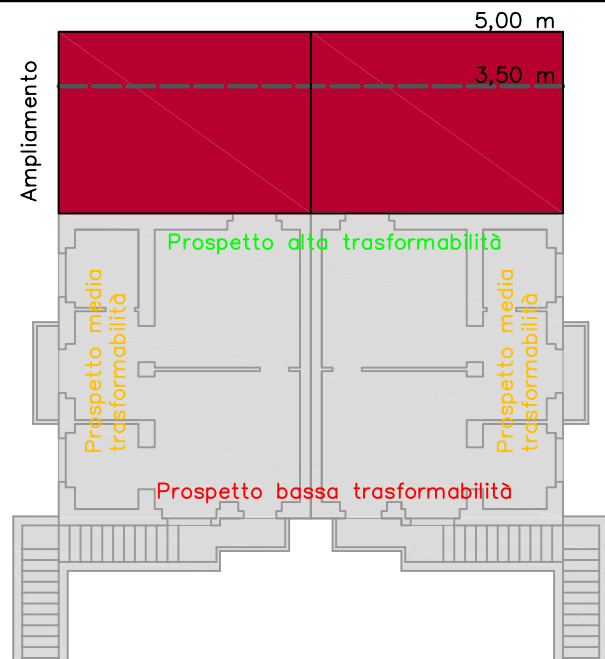

SCHEMA ABACO

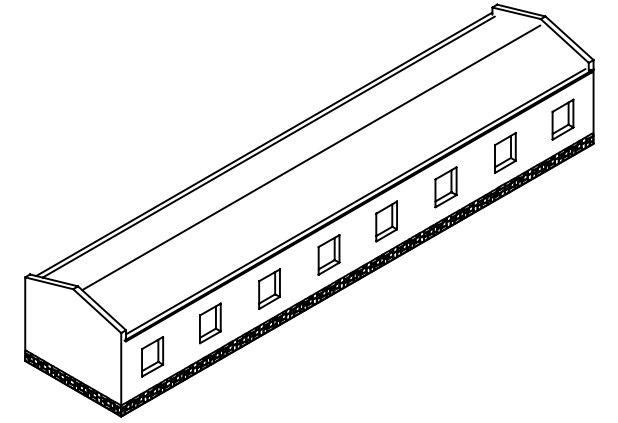
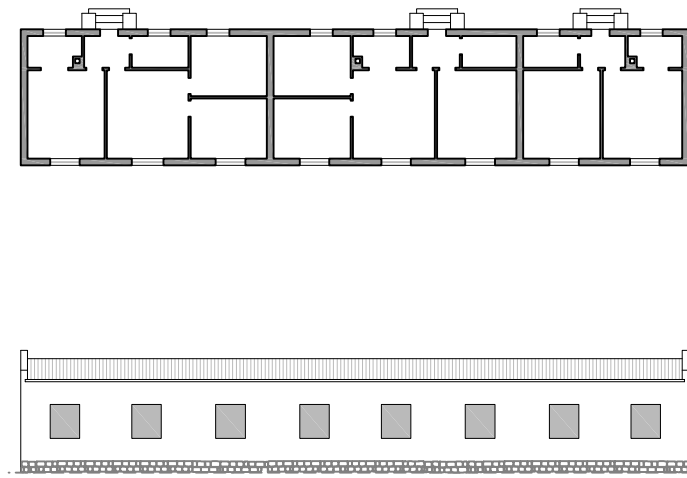

TIPOLOGIA EDILIZIA ORIGINARIA

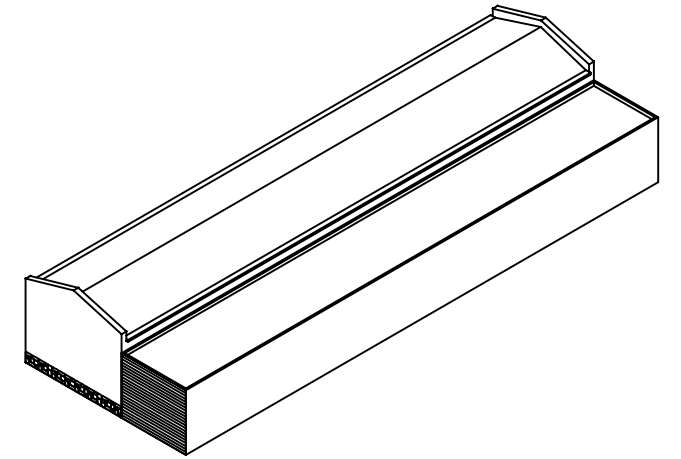
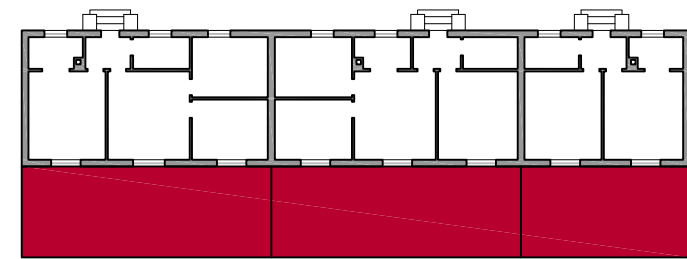

TIPOLOGIA EDILIZIA MODIFICATA

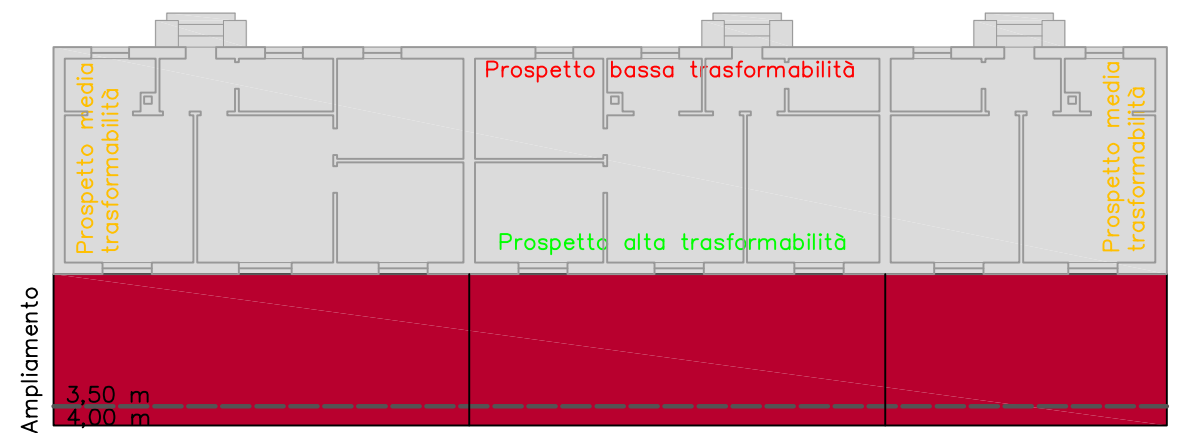

SCHEMA ABACO

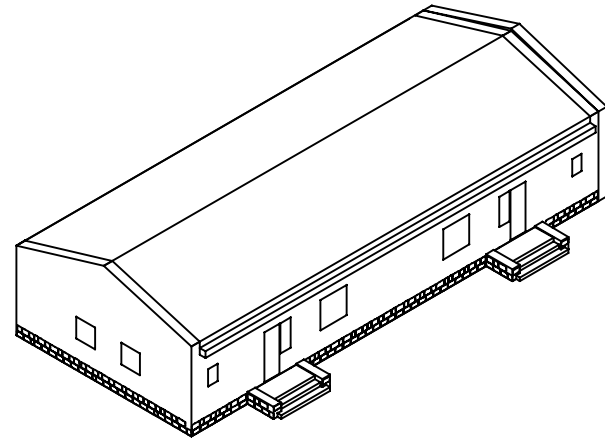
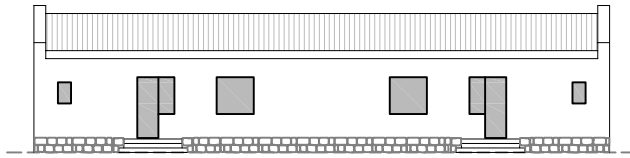
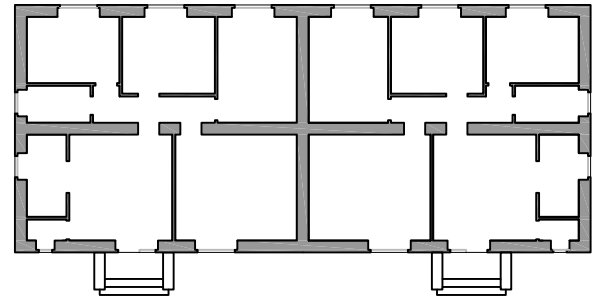

TIPOLOGIA EDILIZIA **ORIGINARIA**

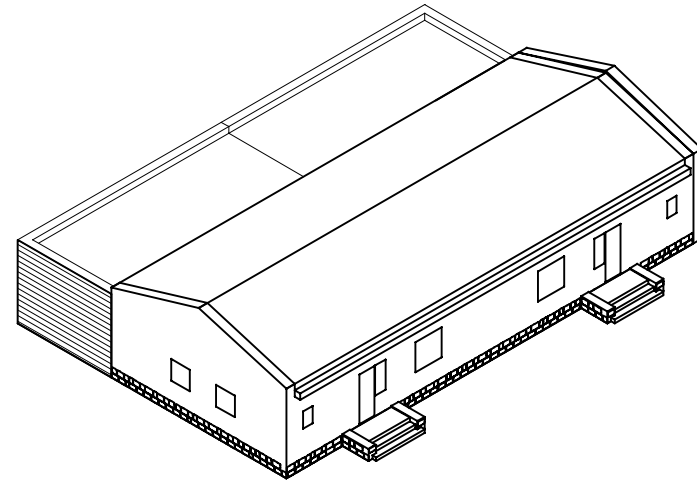
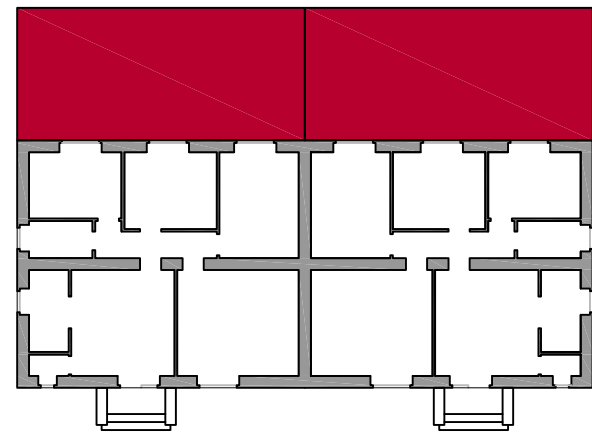

TIPOLOGIA EDILIZIA **MODIFICATA**

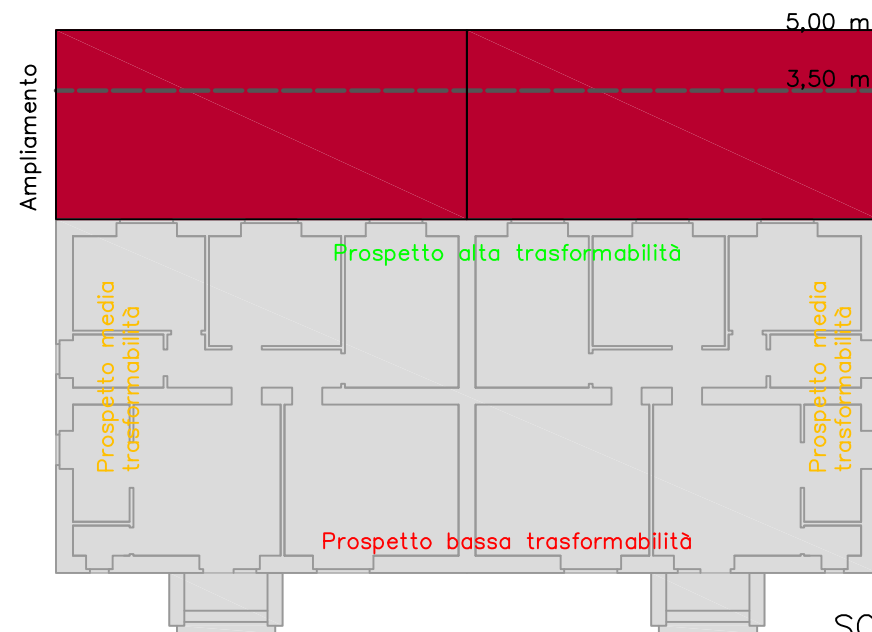

SCHEMA **ABACO**

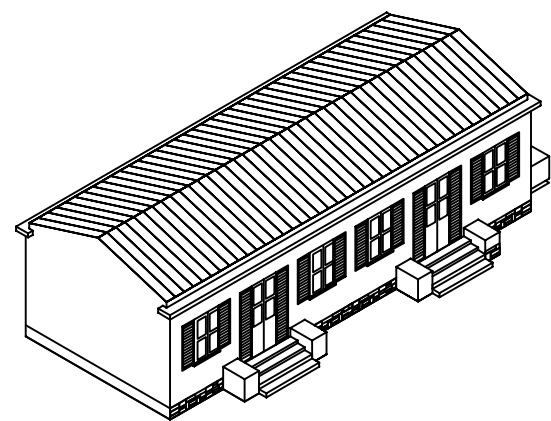
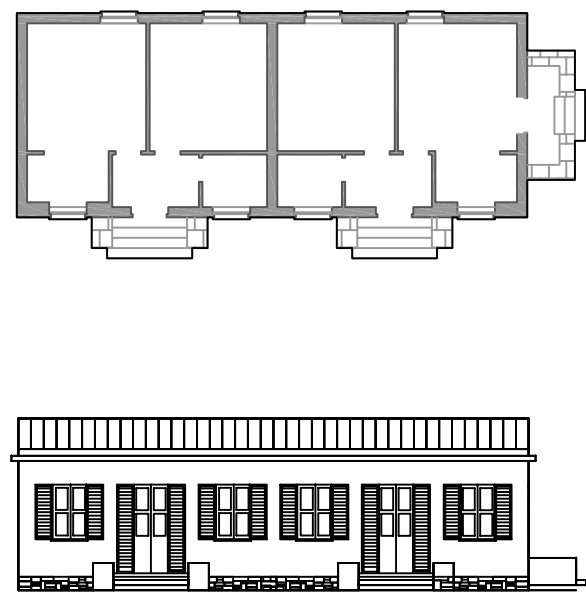

TIPOLOGIA EDILIZIA ORIGINARIA

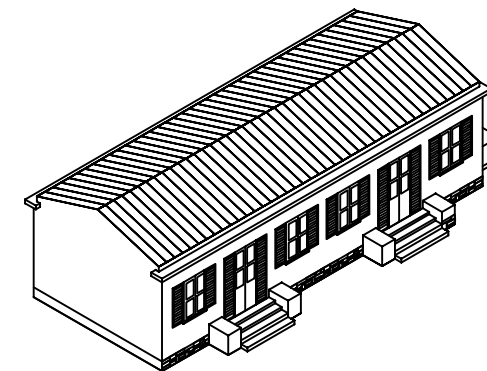
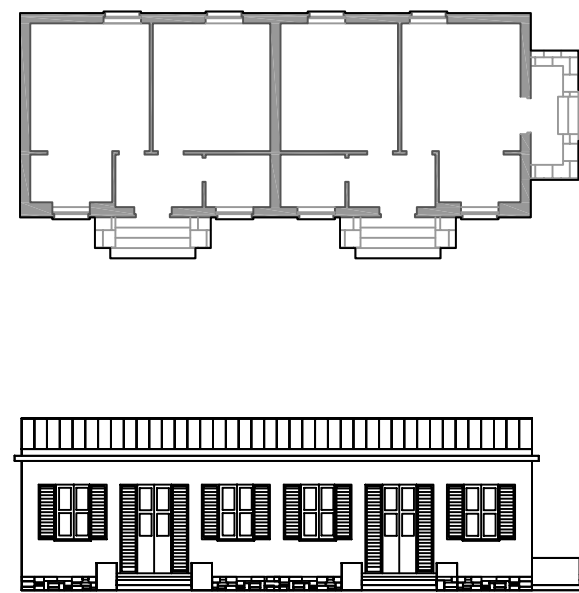

TIPOLOGIA EDILIZIA ORIGINARIA

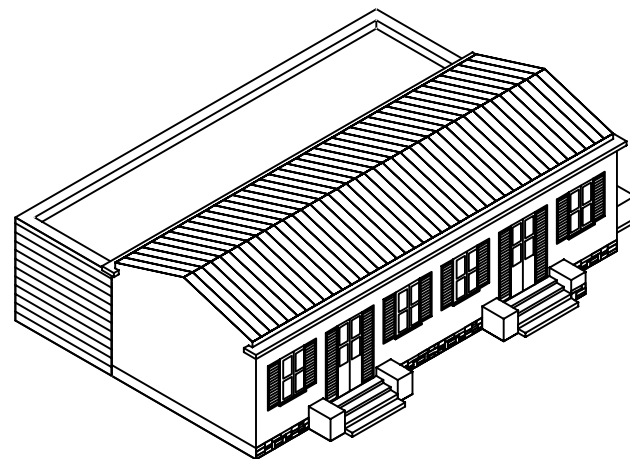
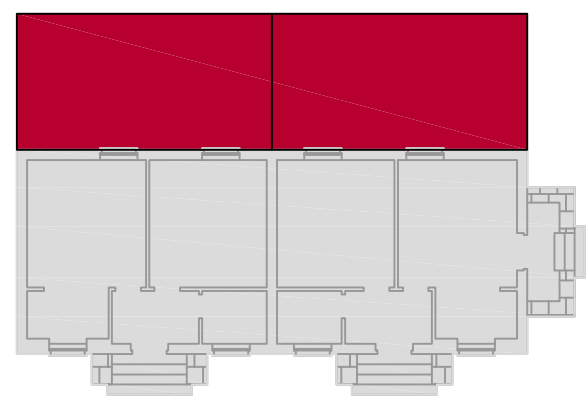

TIPOLOGIA EDILIZIA MODIFICATA

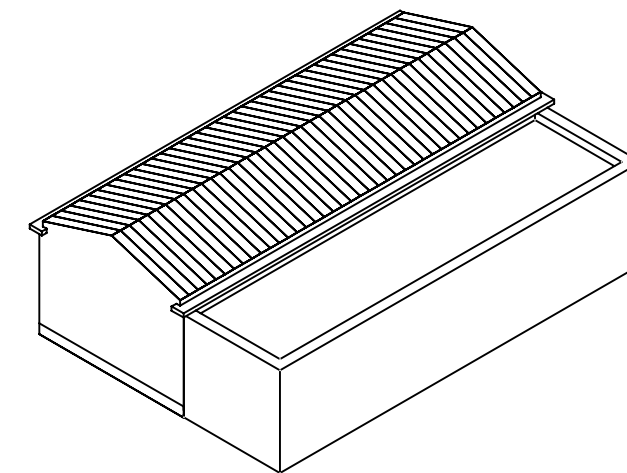
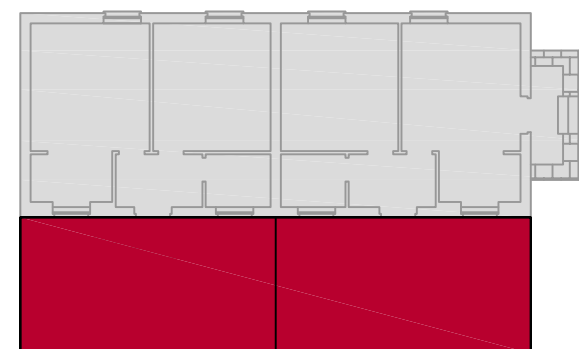

TIPOLOGIA EDILIZIA MODIFICATA

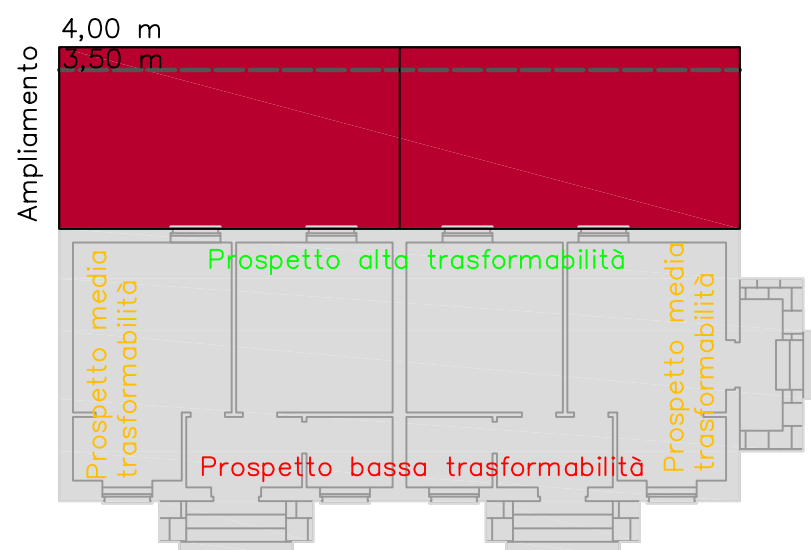

SCHEMA ABACO

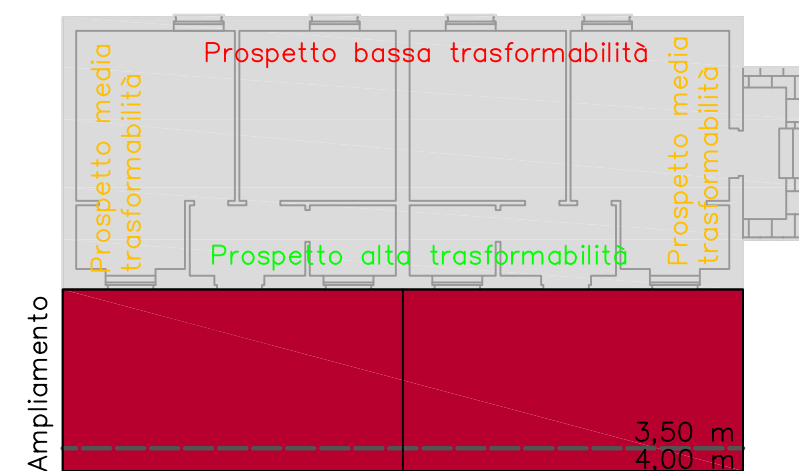

SCHEMA ABACO IN DEROGA



AMBITO DI INTERVENTO

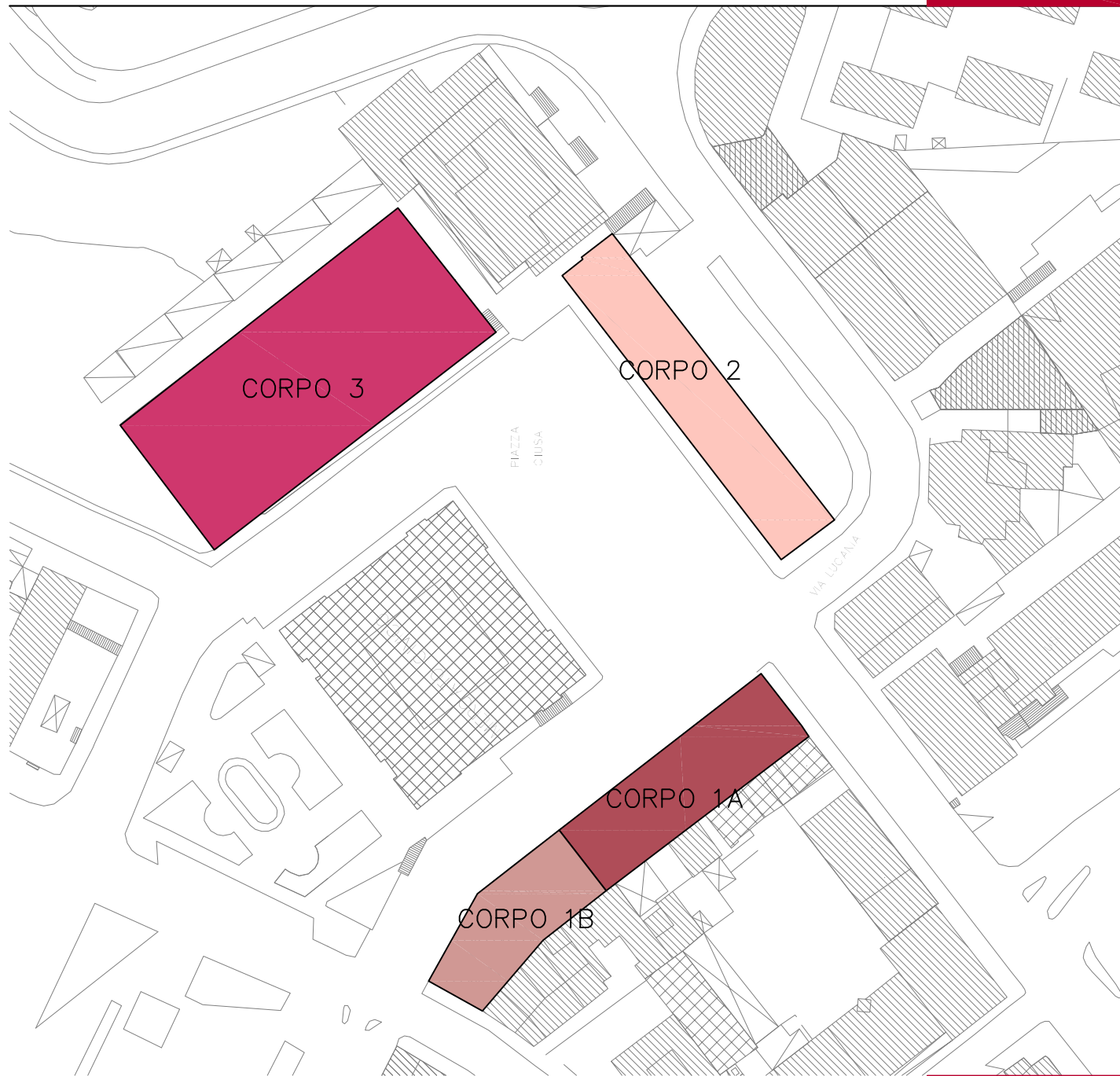

PLANIMETRIA

SCHEMA ADDIZIONI



STATO ATTUALE

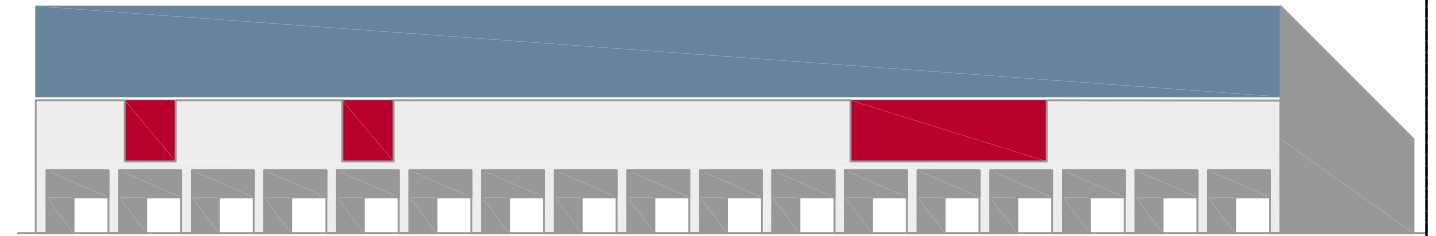

- Completamento del piano primo mediante la realizzazione di nuove addizioni a chiusura dei vuoti esistenti
- Nuove addizioni al piano secondo subordinate alla preventiva realizzazione di una quinta estesa all'intera facciata

INTERVENTI CONSENTITI

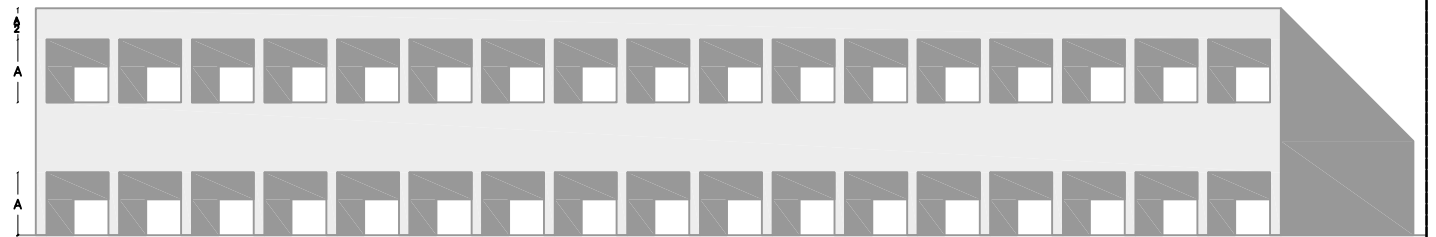

Le nuove addizioni edilizie al piano secondo sono subordinate alla preventiva realizzazione di una quinta estesa all'intera facciata, costituita dal sistema intelaiato pilastri-travi a filo facciata

QUINTA



Le facciate di tamponamento, qualora realizzate a filo della quinta modulare, dovranno essere arretrate di cm 10 rispetto al filo esterno della quinta medesima, al fine di consentirne la corretta lettura

STATO MODIFICATO